



## Woodwork

This sheet includes process of materials other than wood, such as acrylic and bakelite.

### Wood Board

#### \* Cutout

Wood Base, PN5, is cut out from a black-painted wood board whose dimension is 12 x 300 x 150mm.

Tools: power zigsaw, linear guide, flat file, power sander, sandpaper #80, #150

Margin: 2mm

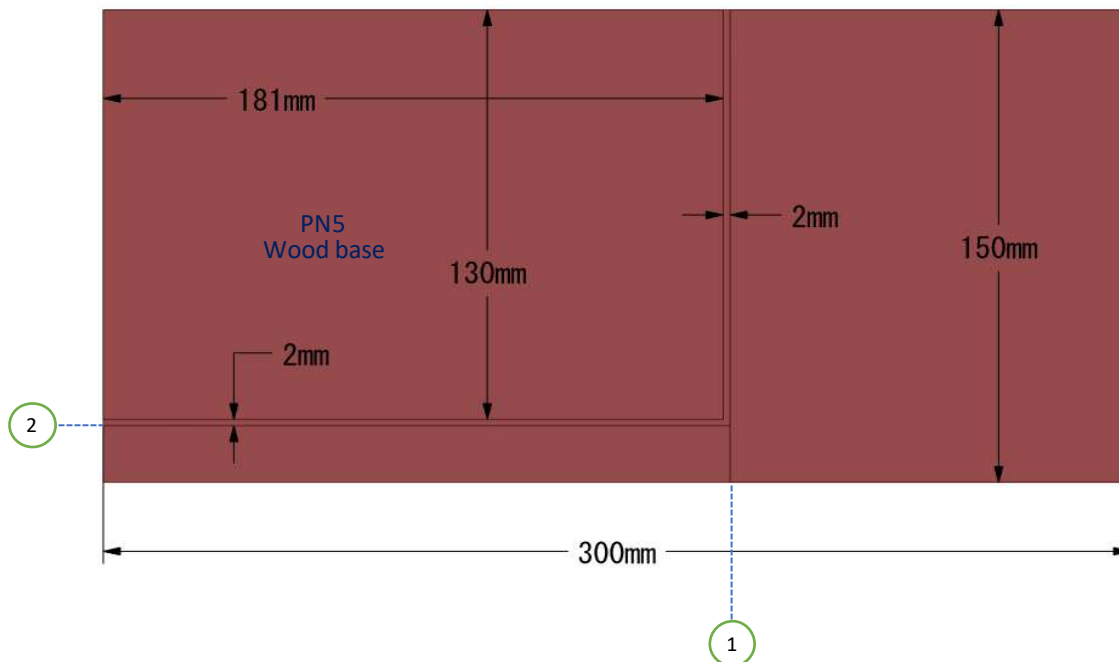

**\* Drilling**

Tools: drilling press, round file

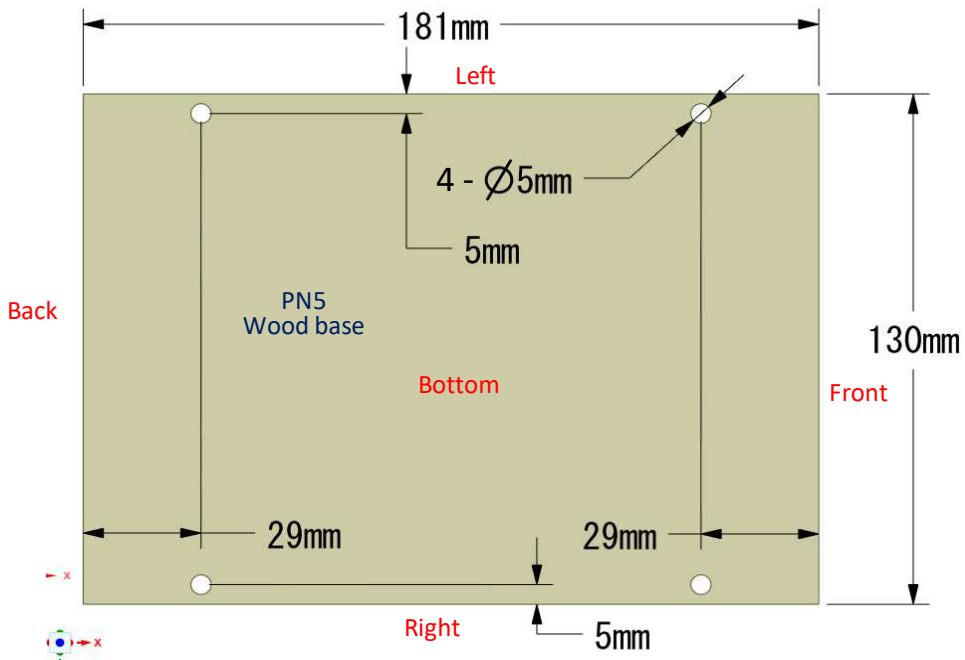

**Wood Round Bar**

**\* Cutout**

No need to cut, since ready-made knob is used.

Ebony wood: phi30, L25

**\* Drilling**

Drill phi6.2 hole in the center of the round bar.

Tools: centerpunch, drilling press, round file, flat file, metal saw

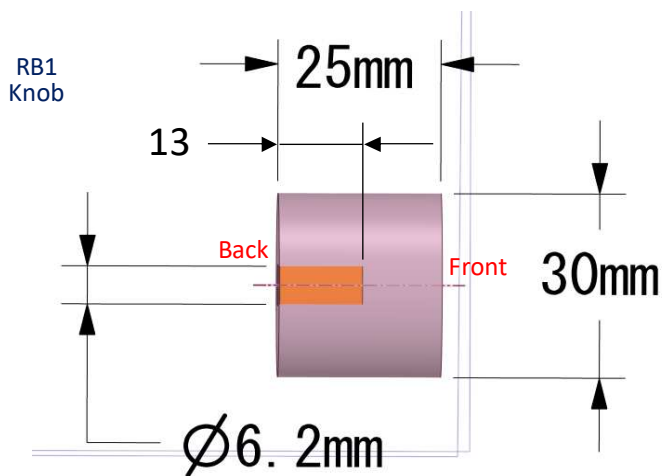

Chamfer the edge of the phi6.2 hole with 6.8MM drill.

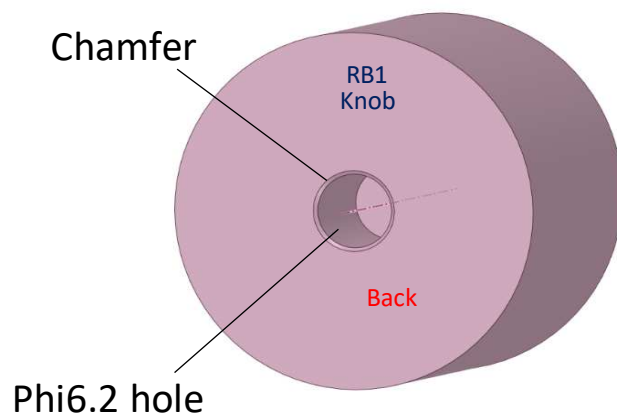

### Bakelite Round Bar

#### \* Cutout

Cut RB2 out of phi6, L430 bakelite round bar.

Tools: coping saw, flat file

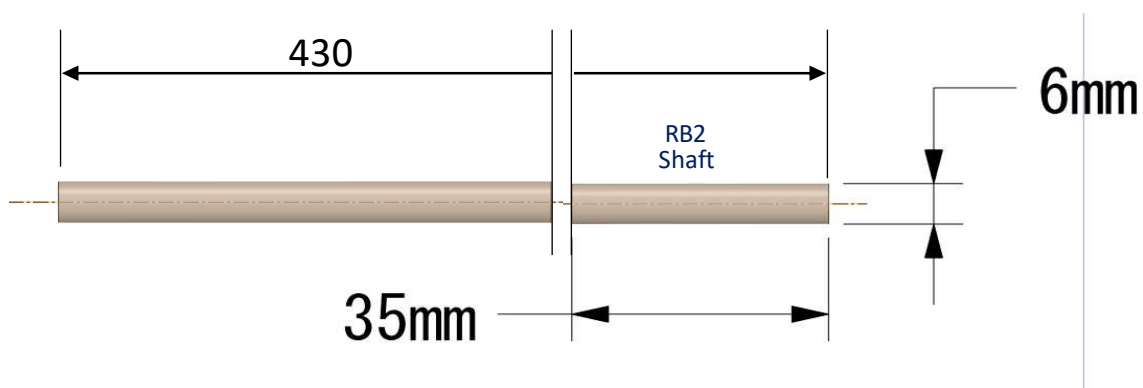

### Universal Board

#### \* Cutout

Cut BD1 (Buffer Board) out of Sunhayato ICB-500F (1.6 x 245 x 195mm universal board).

Tools: coping saw, flat file

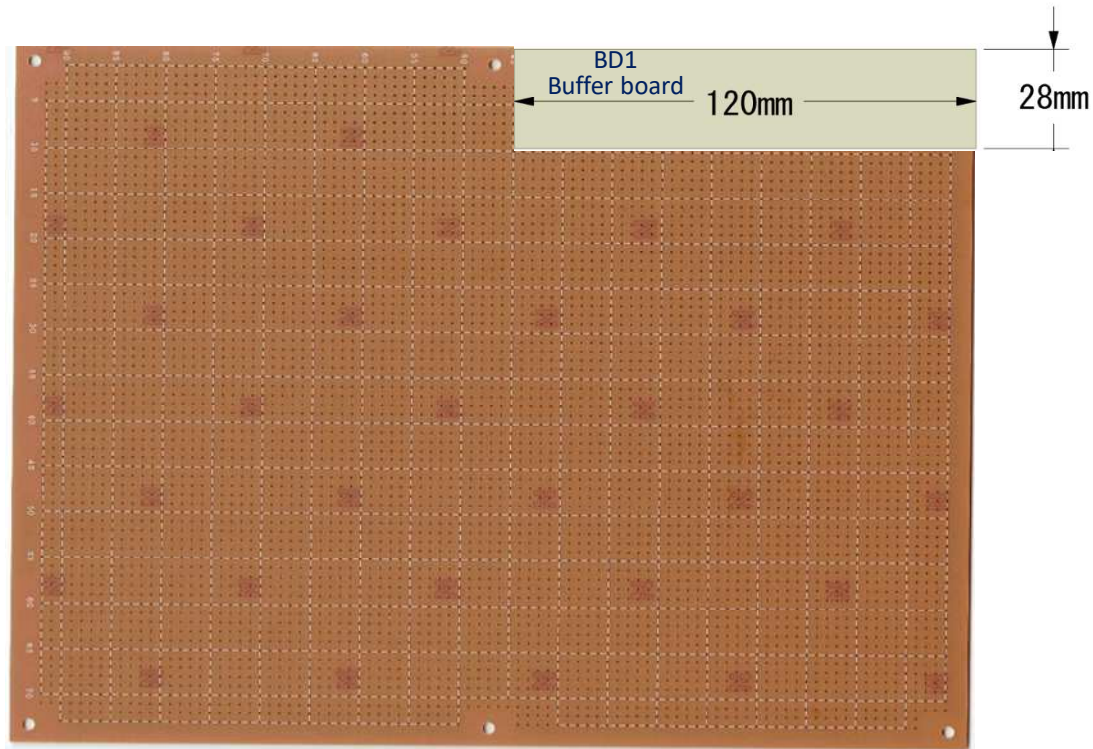

**\* Drilling**

Drill the two (2) screw holes with Phi 3.5 drill.

Tools: drilling press

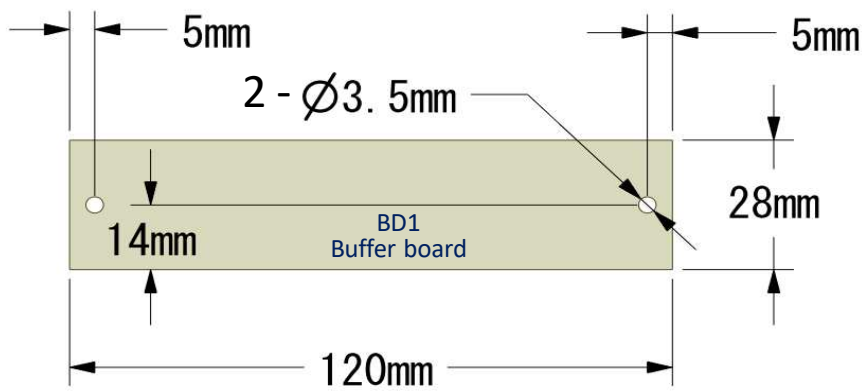

**Clear Panel**

**\* Drilling**

Drill the phi10 hole. (the phi6 holes are already made)

Tools: drilling press

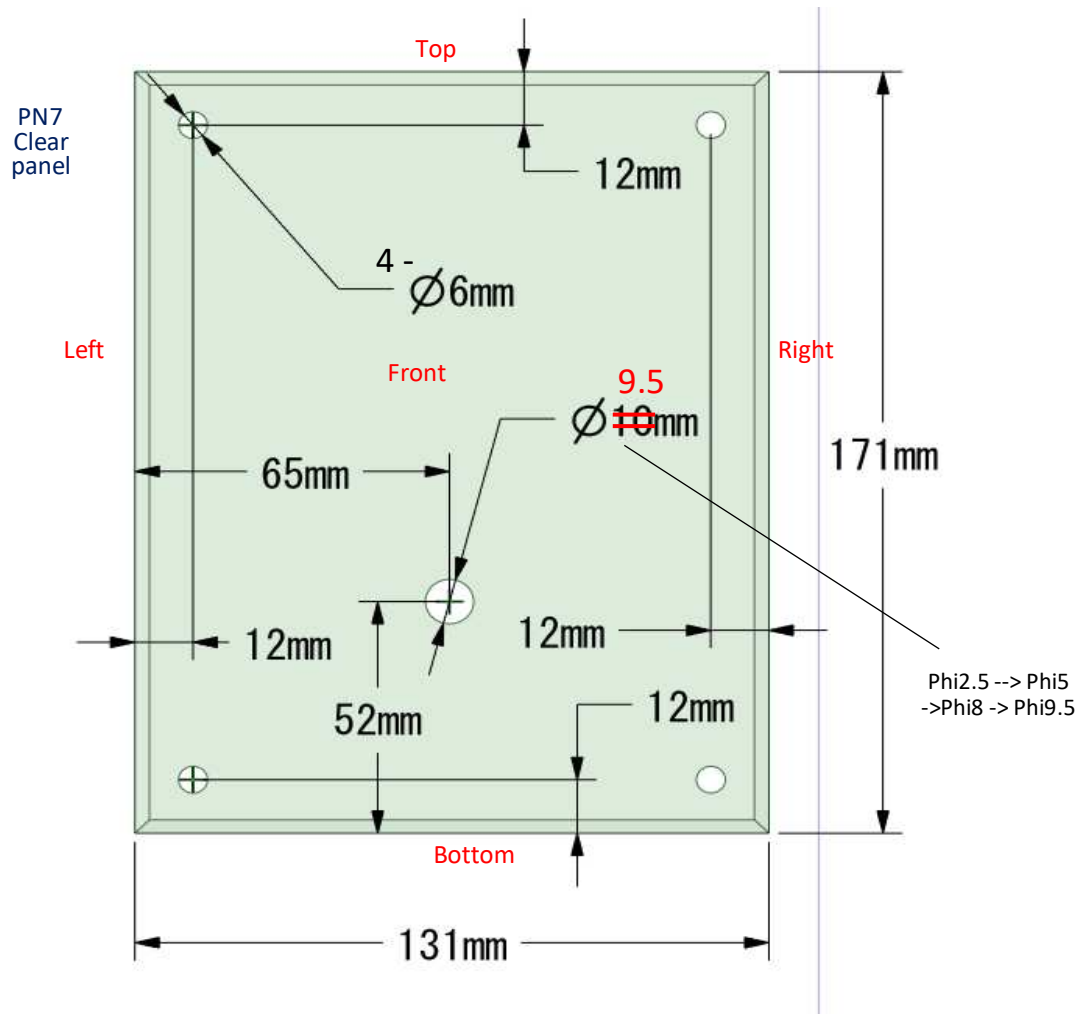

[END OF DOCUMENT]