

Metalwork of MA-215

2014/12/03
2016/01/24 updated

Legend

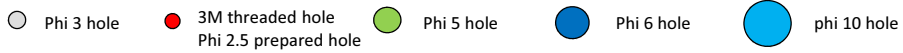

Overall procedure

1. Make the perforated boards PP1-PP6.
2. Preprocess the case C1 and C2, and make the holes in the largest walls of C1 and C2.
3. Remove the paint of the largest walls of C1 and C2.
4. Combined C1 and C2 with screws.
5. Make the holes and cutouts in the case except some of the the holes common with the decorative panels P2 and P5.
6. Make the P2 and P5 with the holes common with the case undrilled.
7. Screwed P2 and P5 to the case temporarily.
8. Make the holes common with the P2 and P5 and the case.
9. Detach P2 and P5 from the case.
10. Make the panels P1, P3, P4, P6, P7, P8, P9 and P10.
11. Make the channels CH1-CH6.
12. Make the L-angel A1-A10.
13. Make the square bar B1-B6.
14. Assemble the case temporarily using all the parts.
15. Detach P1, P2, P7, P8, PP1-PP6, CH5 and CH6.
16. Paint mat black the inside of C1 and C2.C38
17. Paint mat black the face of P7 and P8, the back of P7, and the both sides of PP1-PP6.
18. Affix instant letters to the face of P5 and P6, and paint the faces mat clear.
19. Transfer the letters to the face of P2, and paint the face mat clear.
20. Transfer the letters to the face of P1, and paint the face mat clear.
21. Assemble the case.

Case

Procedure

1. Make mark-off lines.
2. Mark the centers of the holes with a center punch.
3. Drill the holes.
4. Finished the surface of the case.

Preprocess of Lead P-401 (C1, C2)

1.0t 60x180x130 aluminum case painted silver

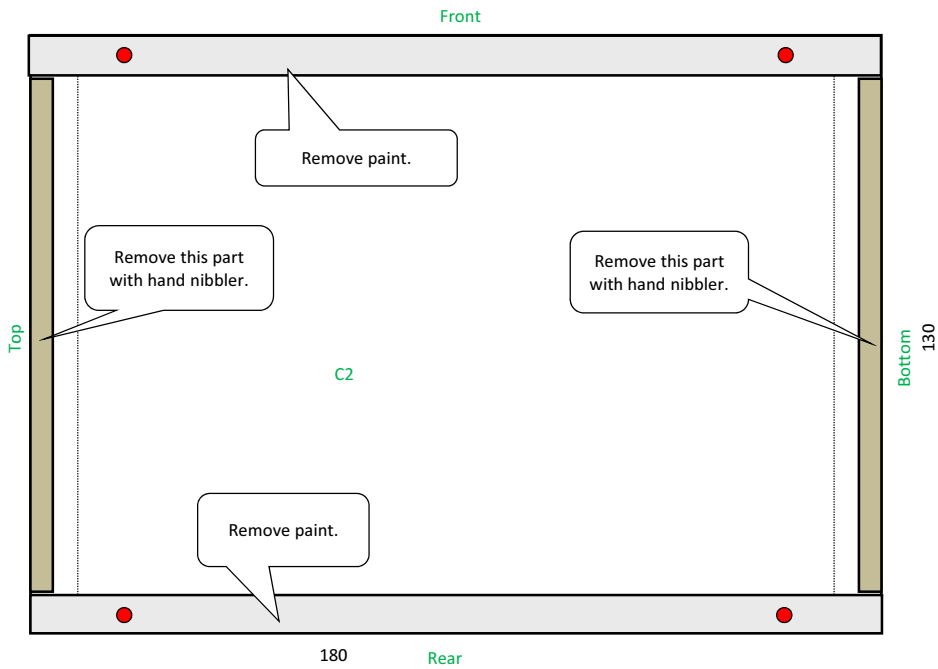
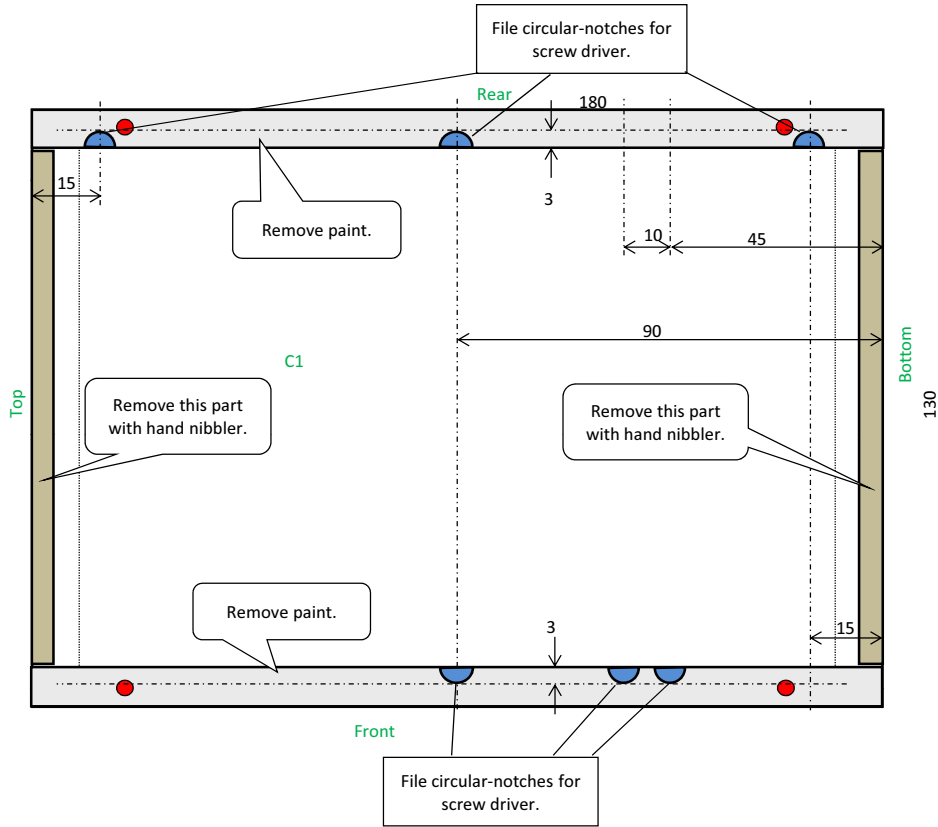

C1: L-oh Case (LEAD P-401)

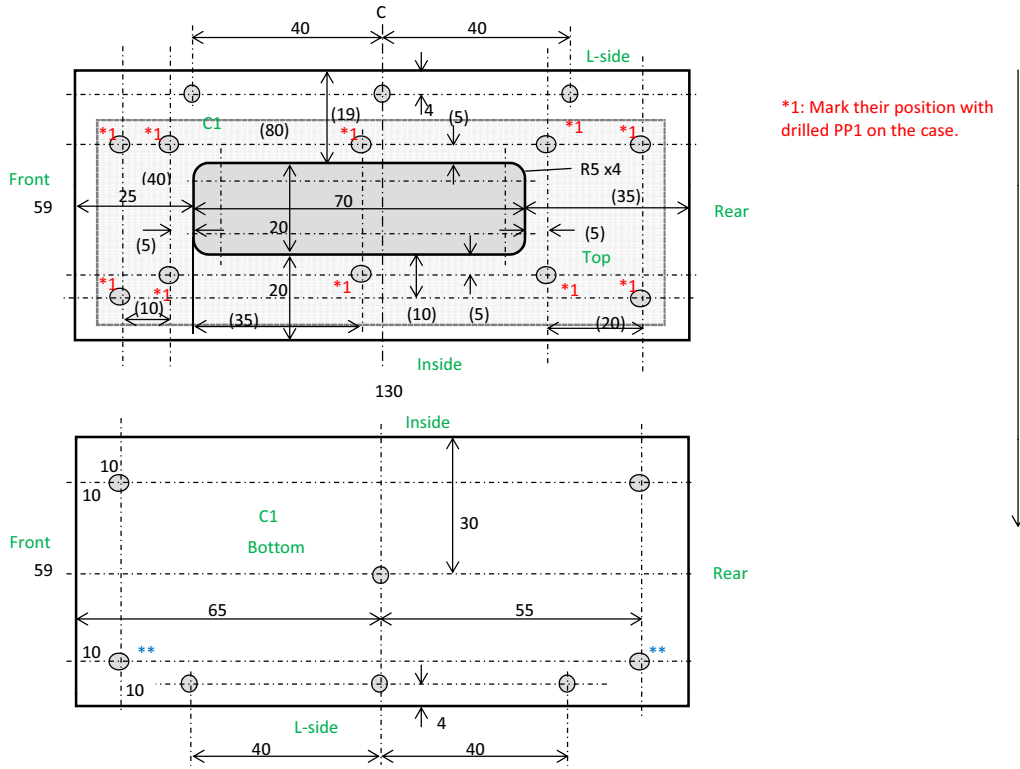

*1: Mark their position with drilled PP1 on the case.

Drill the holes marked with '**' first. ==> These holes are used only for temporal assembly.
 Drill the rest of the holes after P8 is attached.

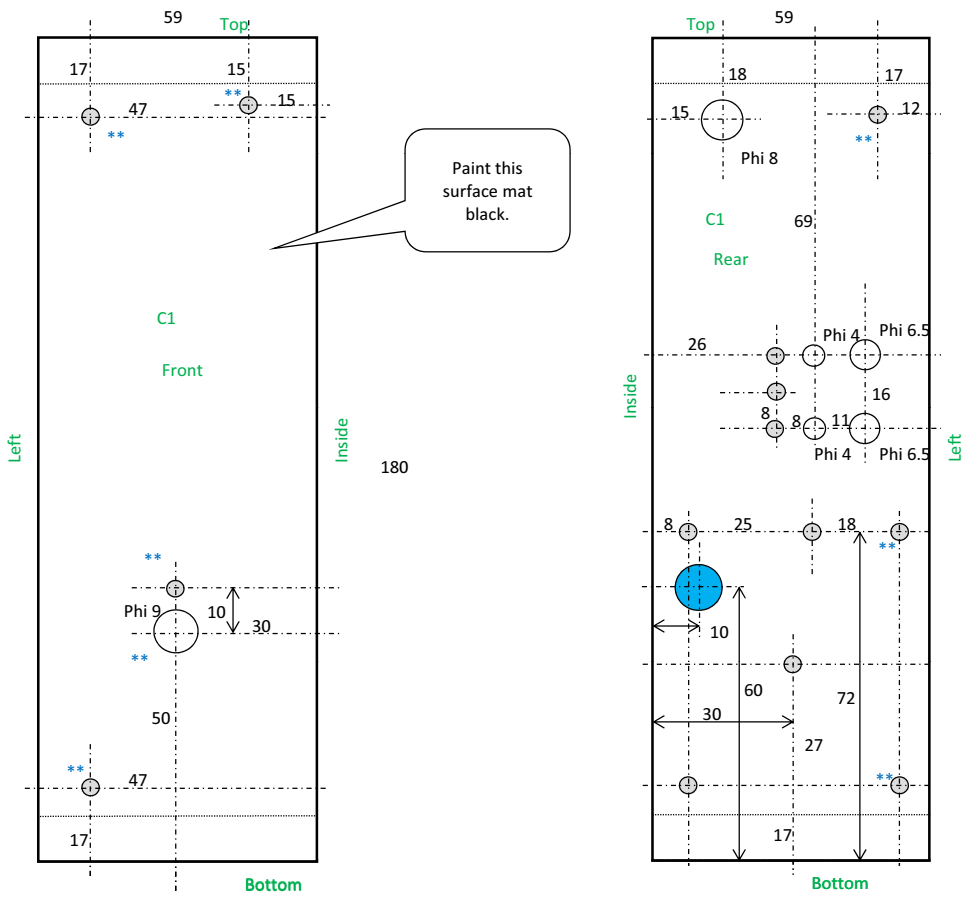

Drill the holes marked with '**' first.
 Drill the rest of the holes after C1 and C2 are combined and P2 and P5 are attached.

C2: R-ch Case (LEAD P-401)

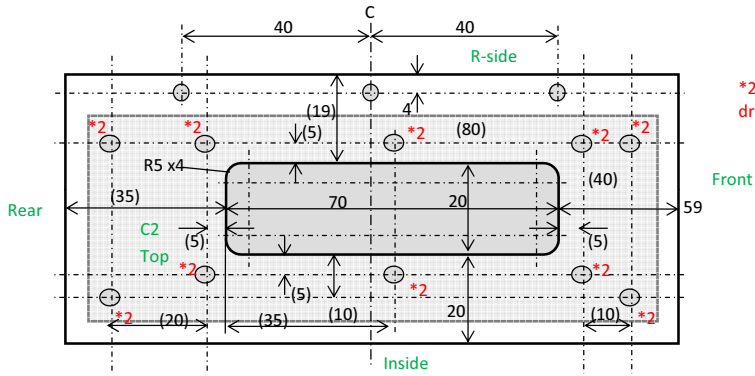

*2: Mark their position with drilled PP2 on the case.

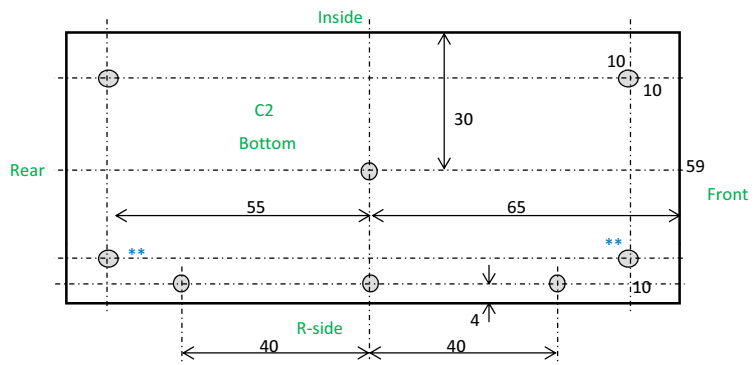

Drill the holes marked with '**' first. ==> These holes are used only for temporal assembly.
 Drill the rest of the holes after P8 is attached. to the case.

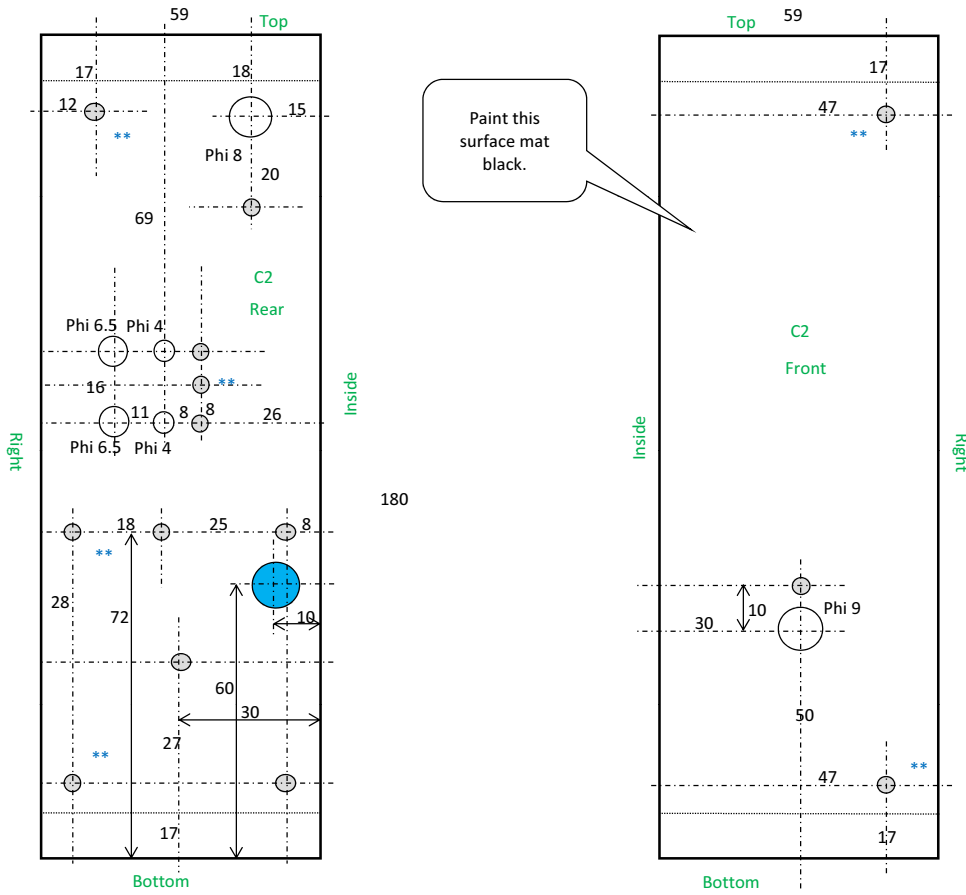

Drill the holes marked with '**' first.
 Drill the rest of the holes after C1 and C2 are combined and P2 and P5 are attached.

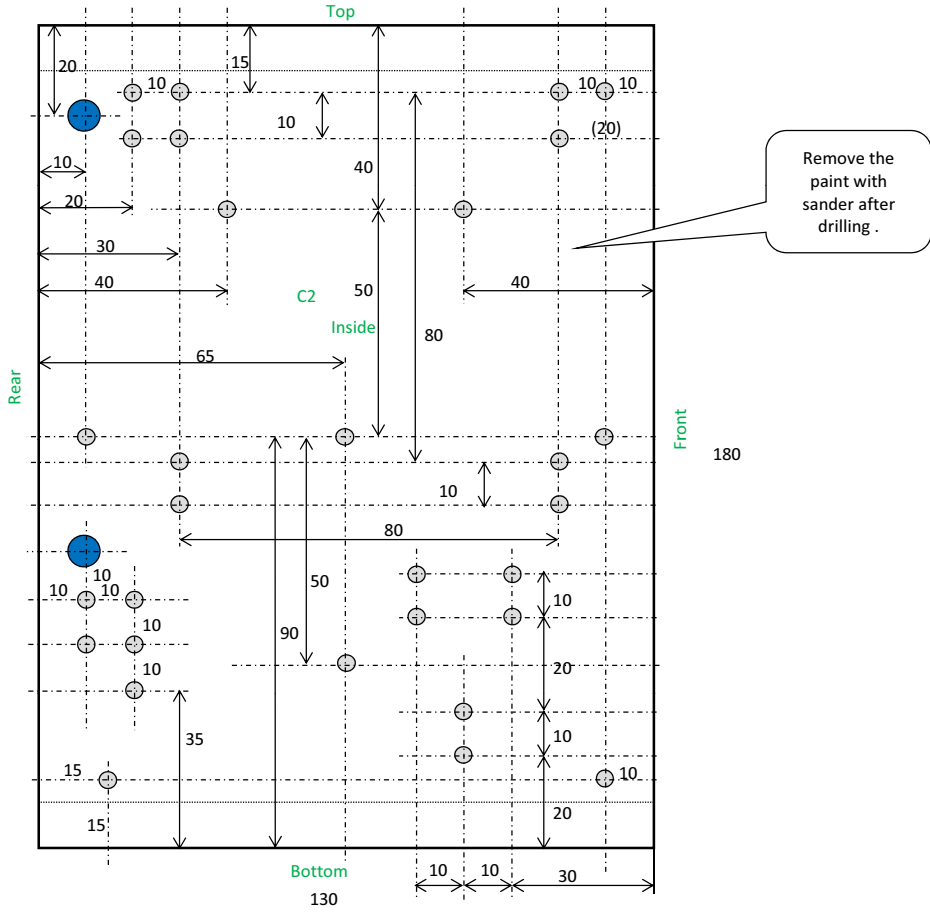

Panels

Procedure

1. Cut out the panel from the standard size panel.
2. Make mark-off lines.
3. Mark the centers of the holes with a center punch.
4. Drill the holes.
5. Finish the surface of the panel.

LEAD NP22 for P1 and P2 (Scale 1/2)
 1.5t silver painted aluminum panel

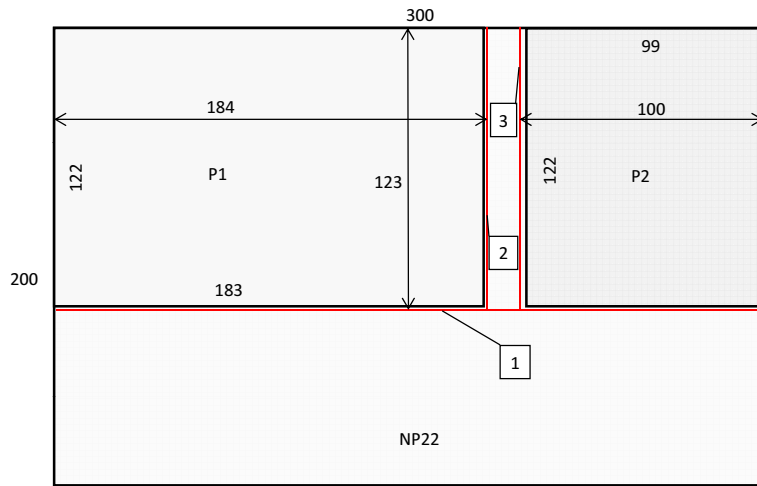

- 1-2: Groove the red line with a gimlet and repeatedly bend the panel till it is cut apart.
- 3: Cut with jigsaw.

P1: Front face panel (LEAD NP22)

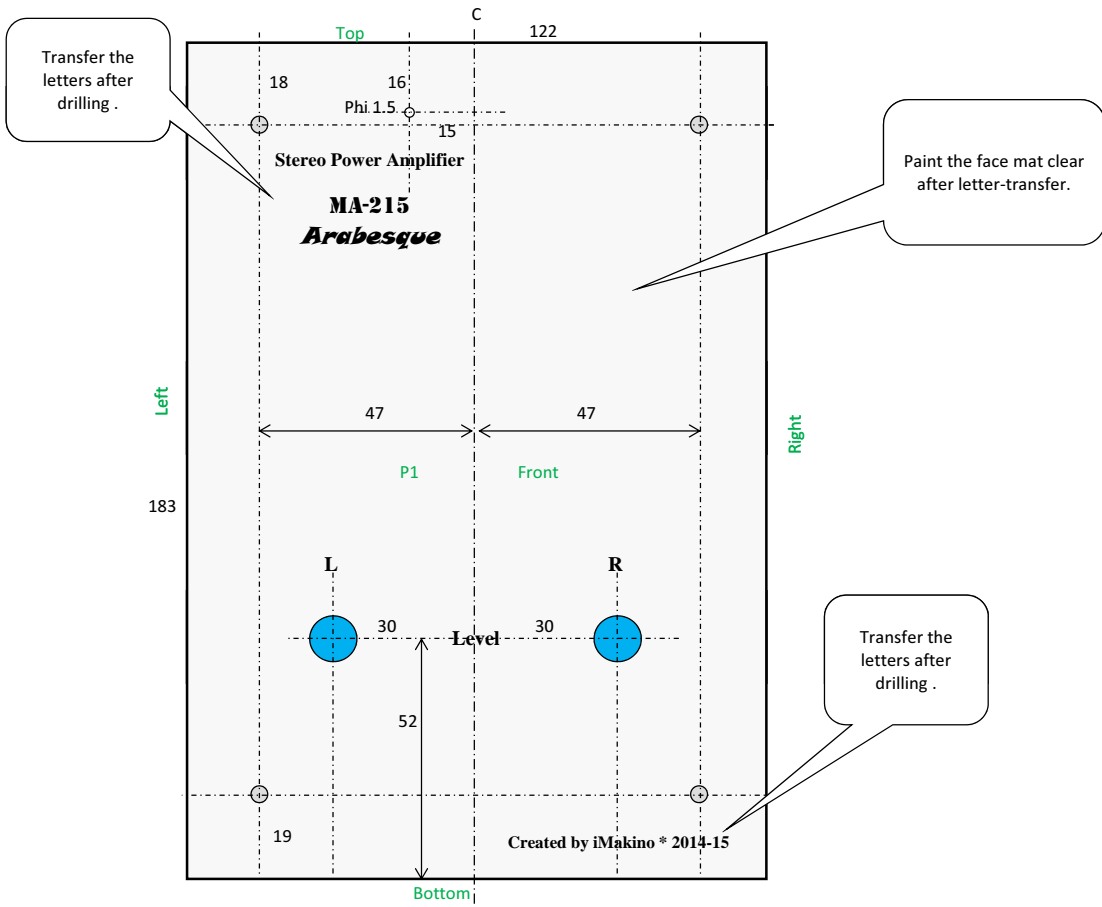

After transferring the letters, spray the surface with mat clear paint.

P2: Rear face panel (LEAD NP22)

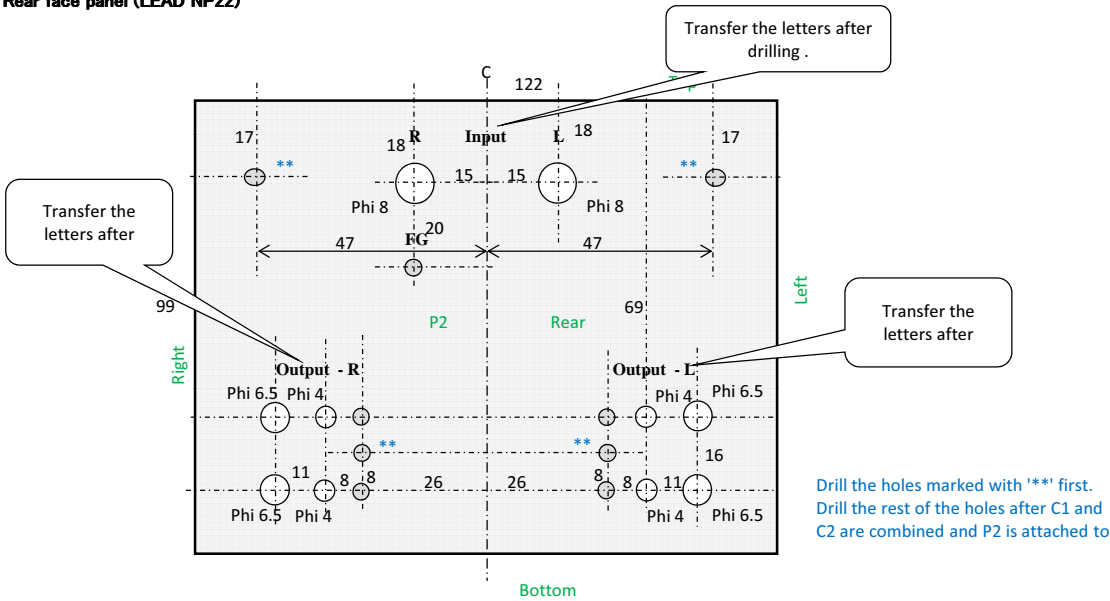

After transferring the letters, spray the surface with mat clear paint.

Letters for P1 and P2

Print this page on a transfer sheet.

Stereo Power Amplifier

MA-215

Arabesque

Created by iMakino * 2014-15

L

R

FG

Level

R

Input

L

Output - R

Output - L

Stereo Power Amplifier

MA-215

Arabesque

Created by iMakino * 2014-15

L

R

FG

Level

R

Input

L

Output - R

Output - L

P3: Side panel L (LEAD P-401)

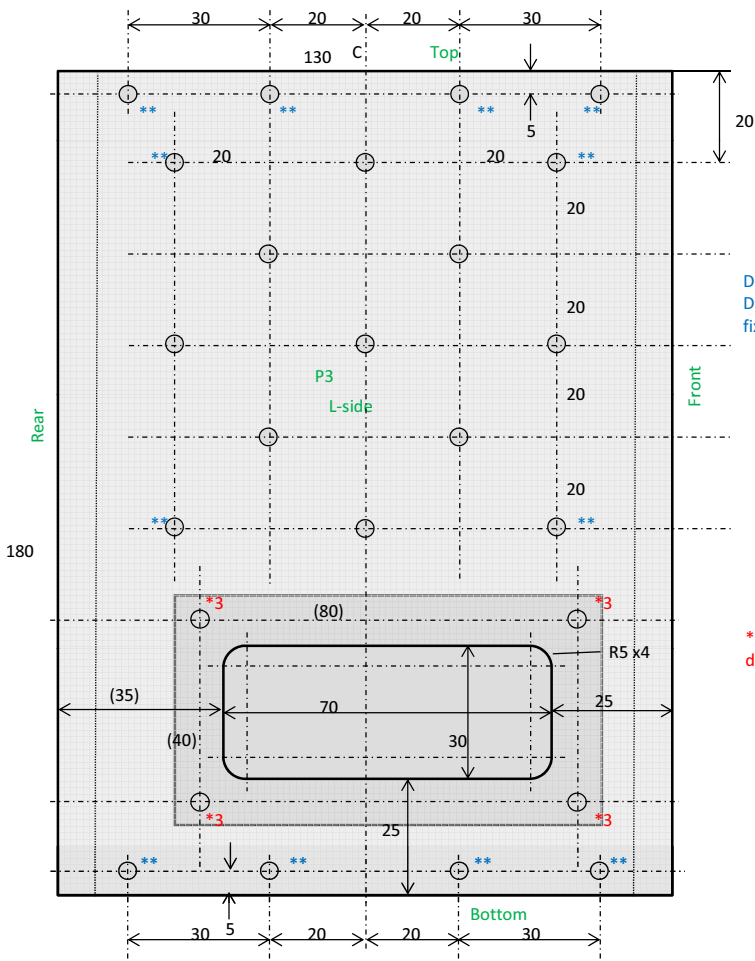

Drill the holes marked with '**' first.
Drill the rest of the holes after P9 is fixed to P3.

*3: Mark the position with drilled PP3 on P3.

P4: Side panel R (LEAD P-401)

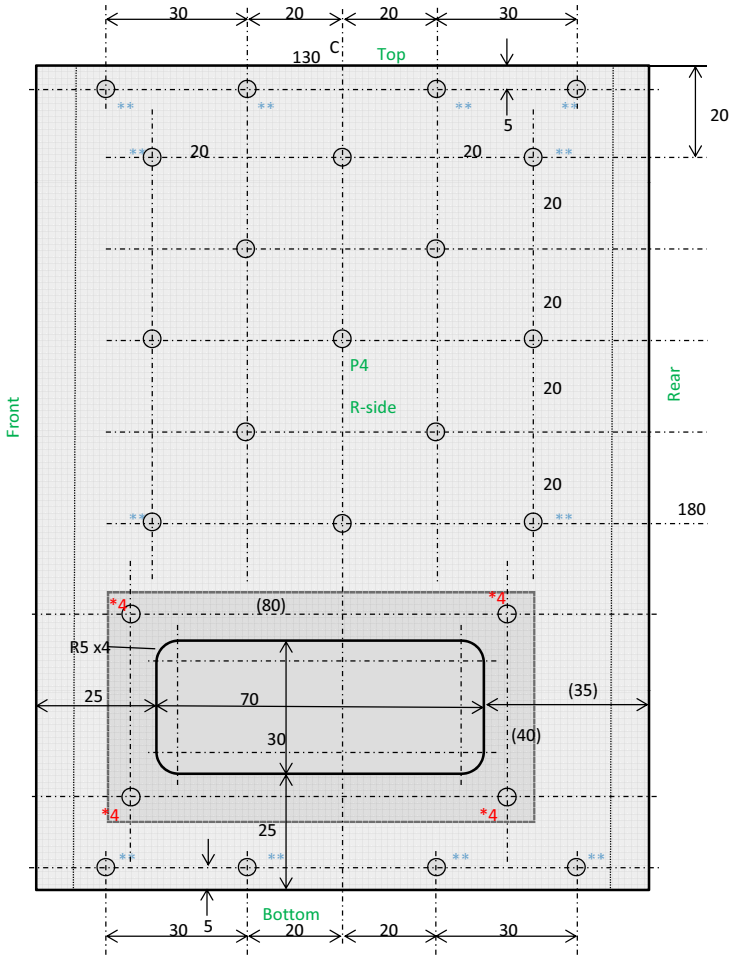

Drill the holes marked with '**' first. Drill the rest of the holes after P10 is attached to P4.

*4: Mark the position with drilled PP4 on P4.

Takachi K-113 for P5 and P6 (Scale: 1/2)
1.5t black painted aluminum panel

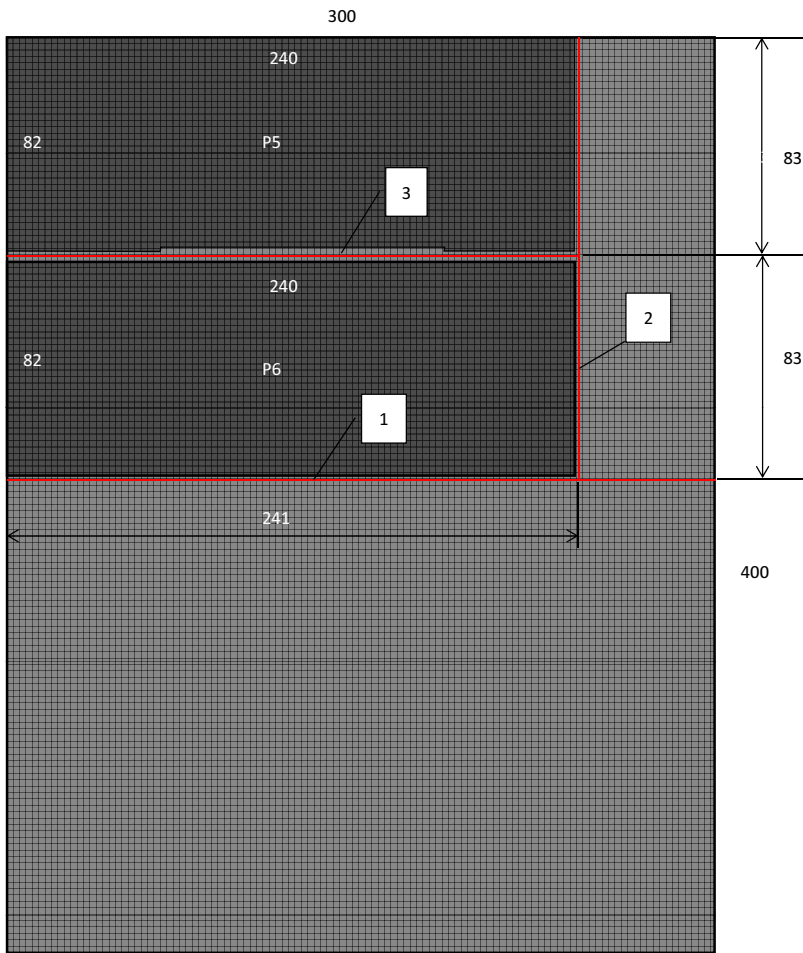

Cut with jigsaw.

P5: Front face panel PS (Takachi K-113)
 1.5t black painted aluminum panel

Front side

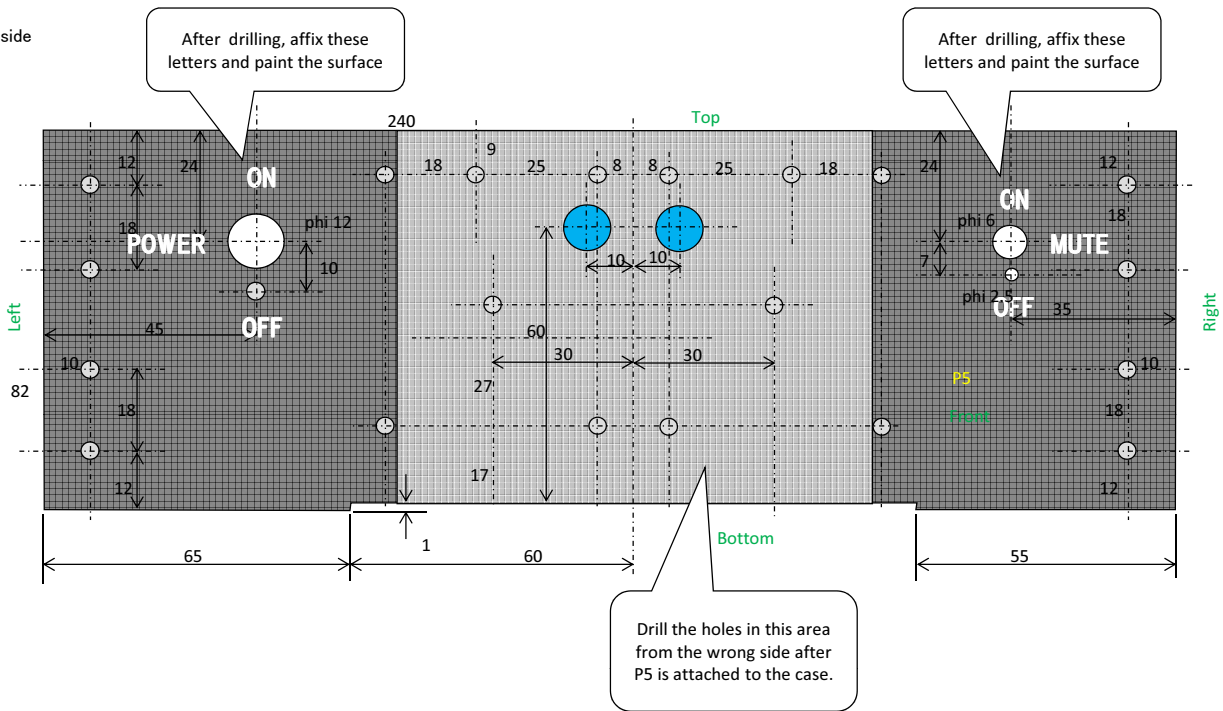

Rear side

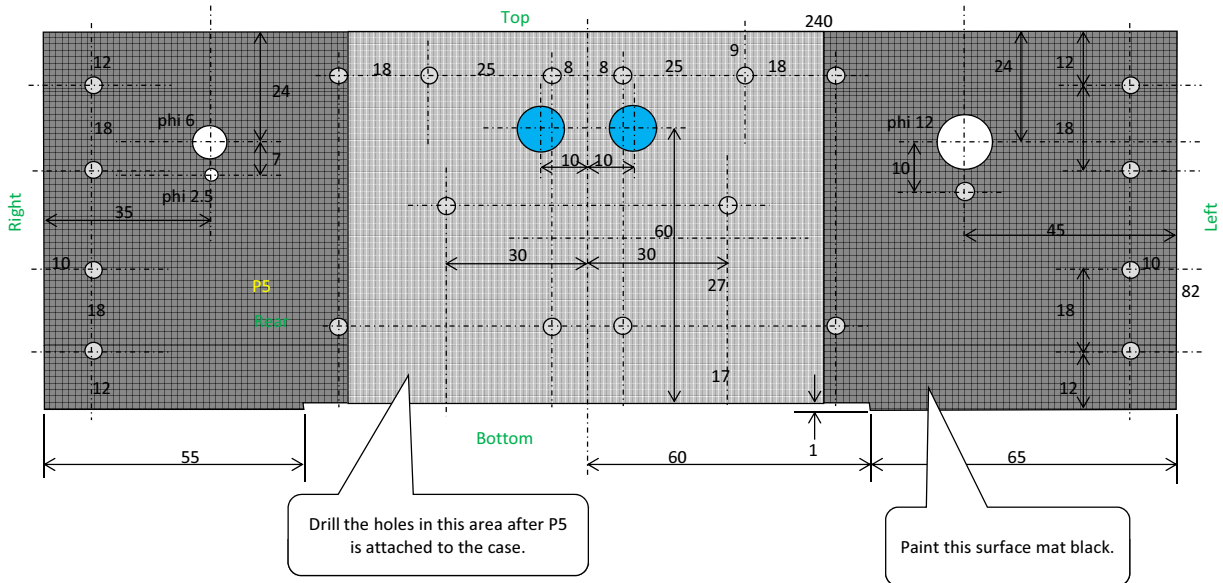

P6: Rear face panel PS (Takachi K-113)

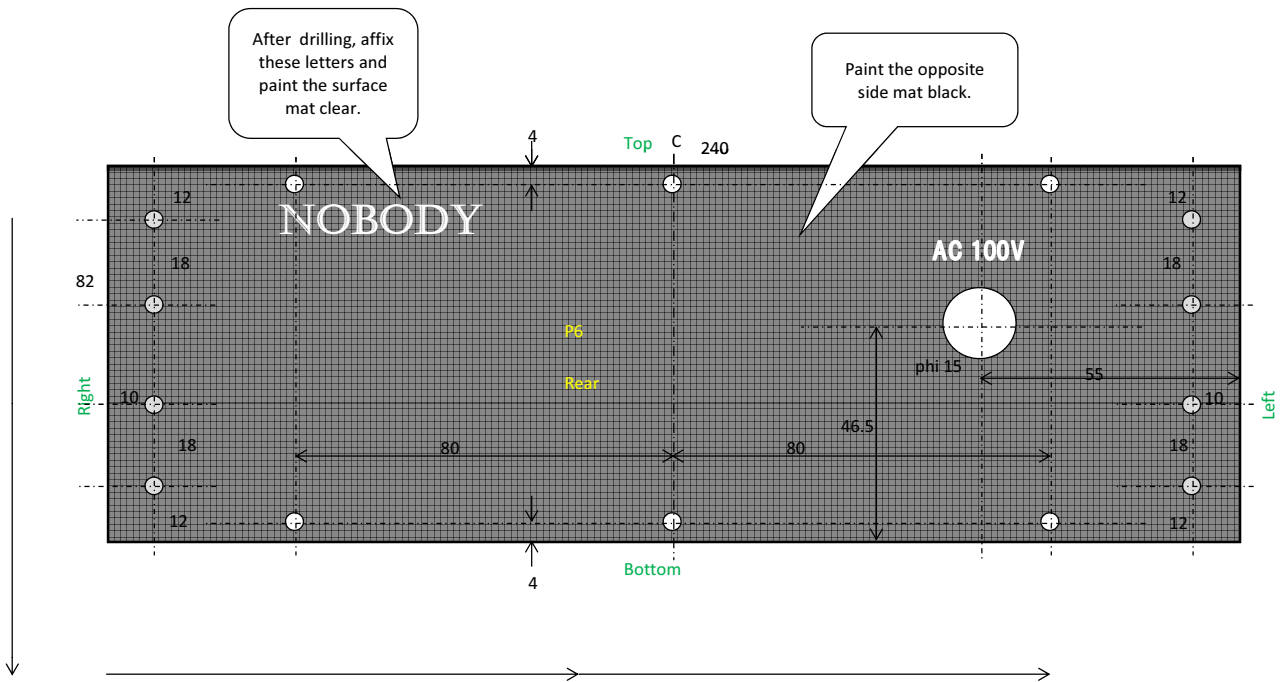

Eggs B(CS) Aluminum board 1.0x400x600mm (Scale: 1/2) for P7 and P8

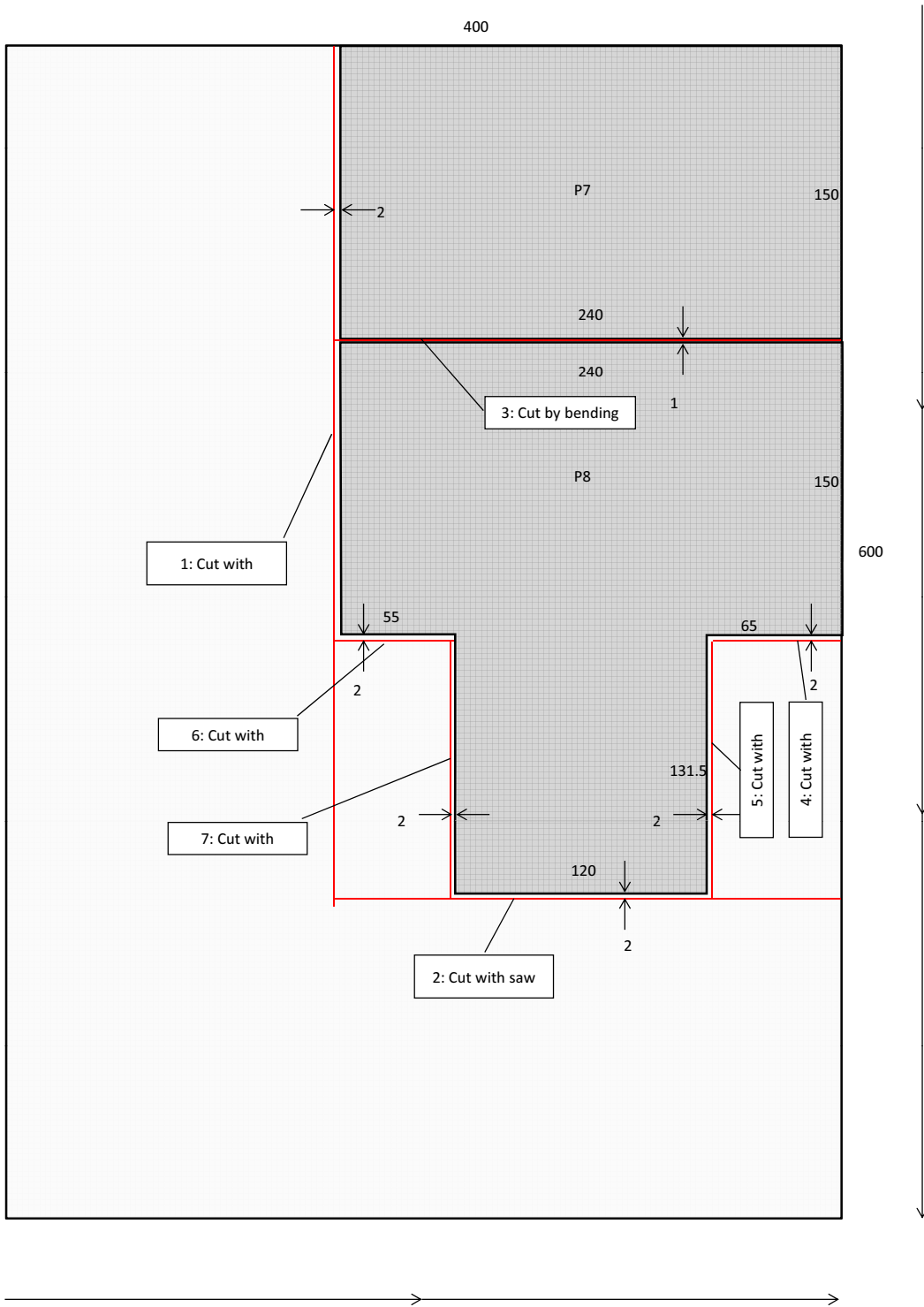

P7: Top panel PS

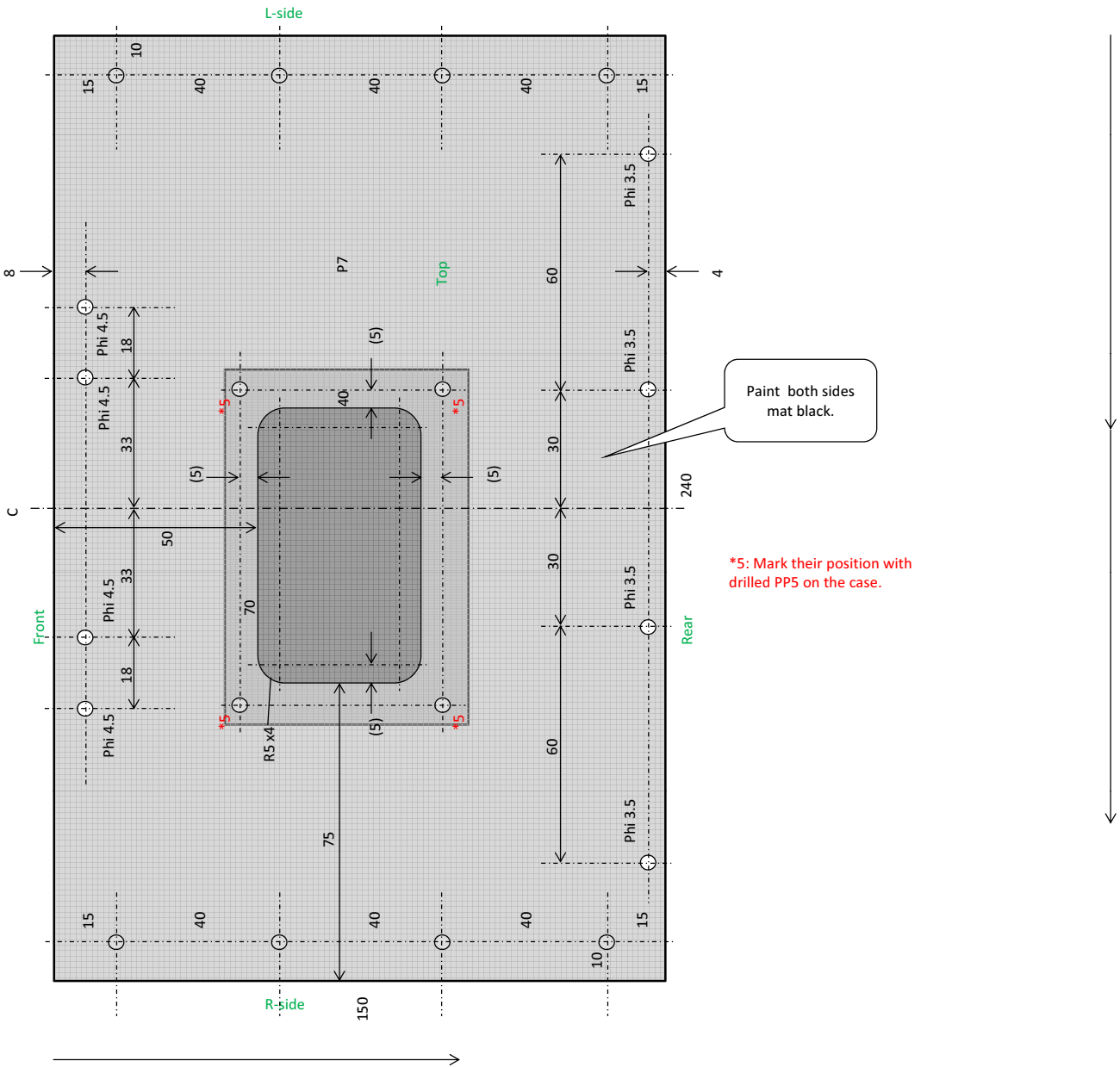

Takcshi C-5 copper board 1.0x200x100mm for P9 and P10

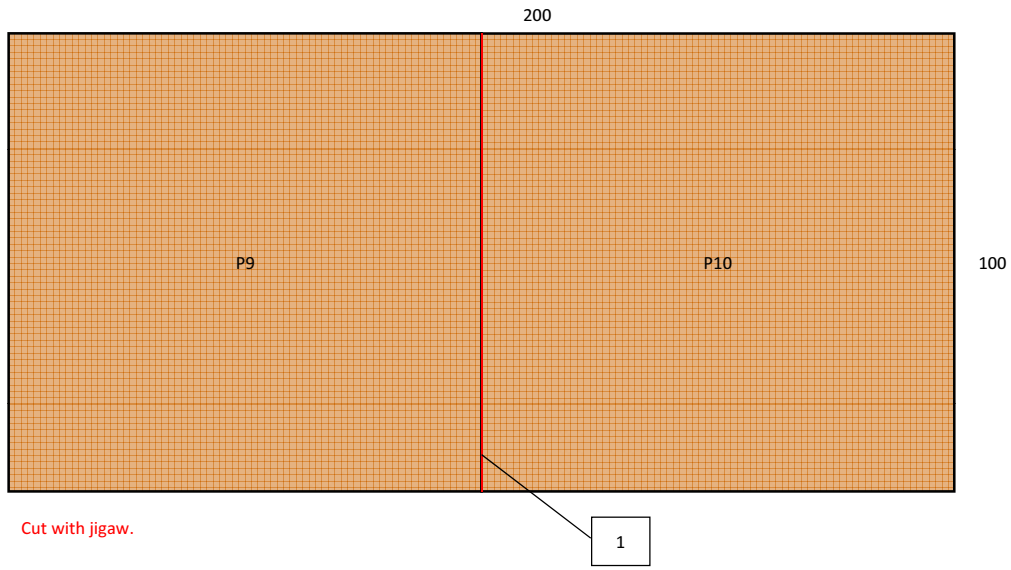

P9: Reinforce panel L

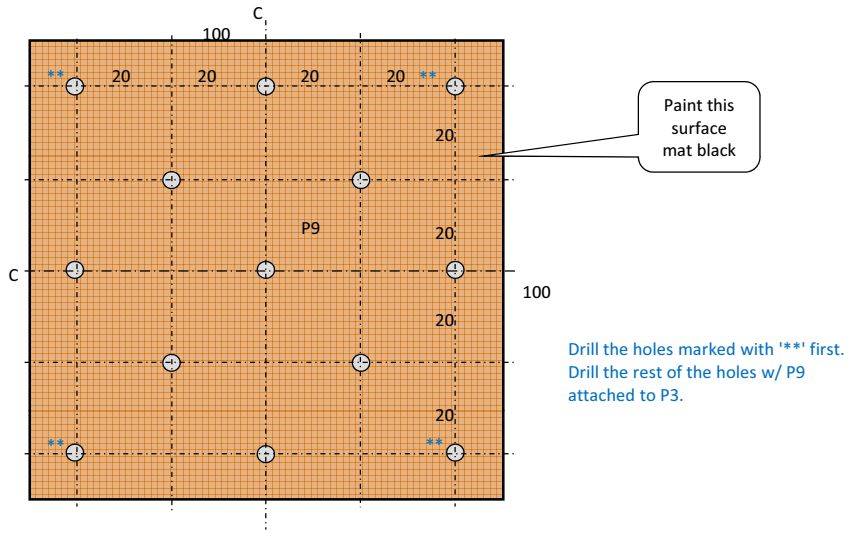

P10: Reinforce panel R

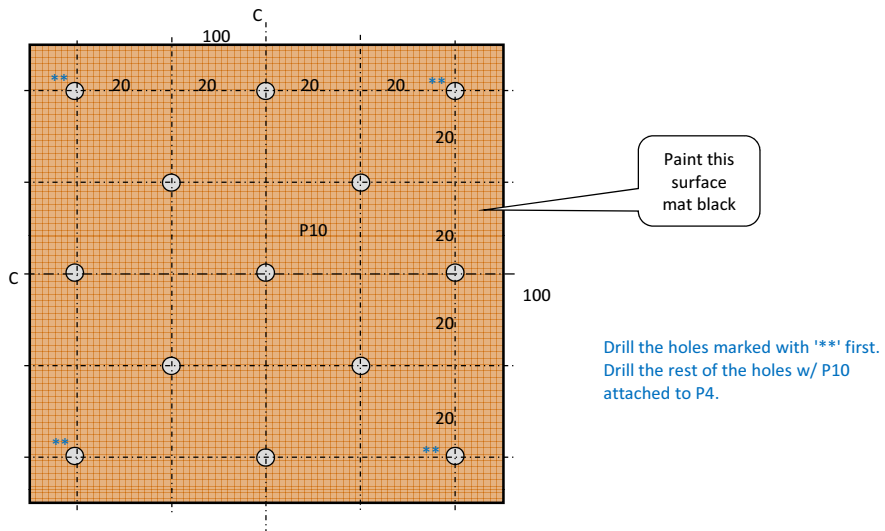

Perforated panels

Procedure

1. Cut out the panel from the standard size panel.
2. Make mark-off lines.
3. Enlarge the holes by drilling.
4. Finish the surface of the panel.

Takachi PA-23 Al perforated panel for PP1, PP2, PP3, PP4, PP5 and PP6 (Scale: 1/2)
1.0t aluminum perforated panel

Cut with jigsaw.

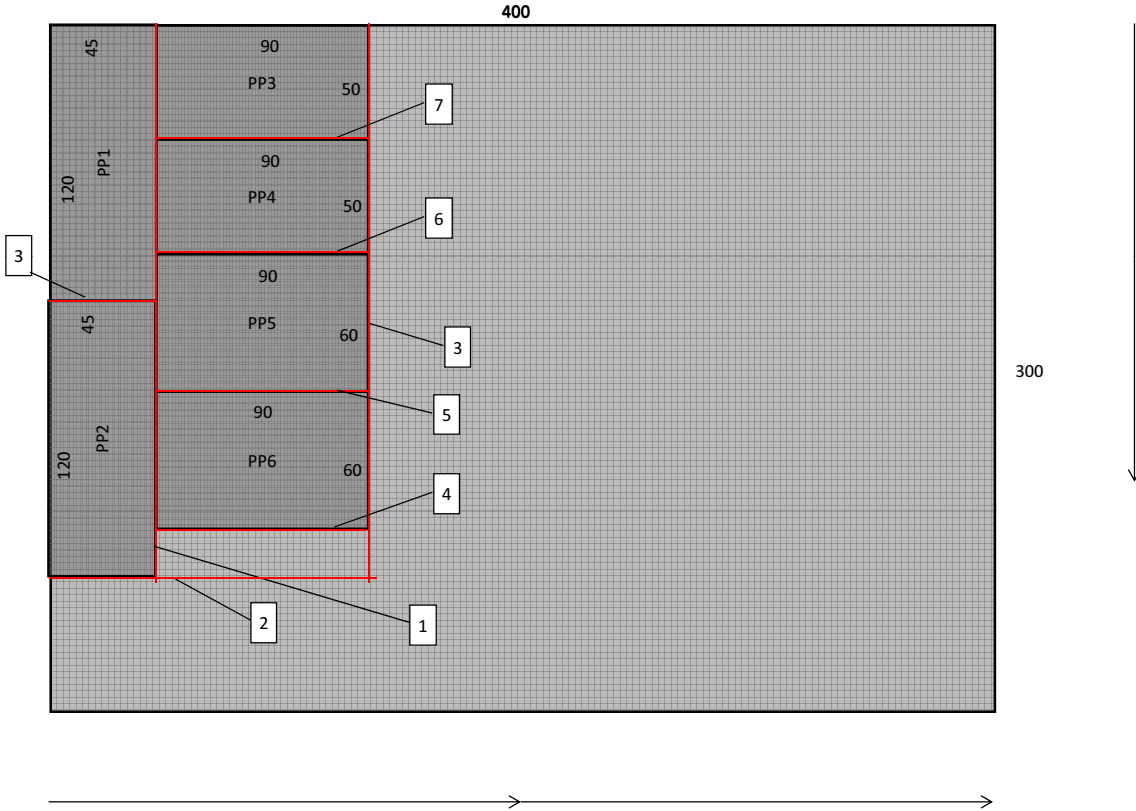

PP1: Top perforated panel L

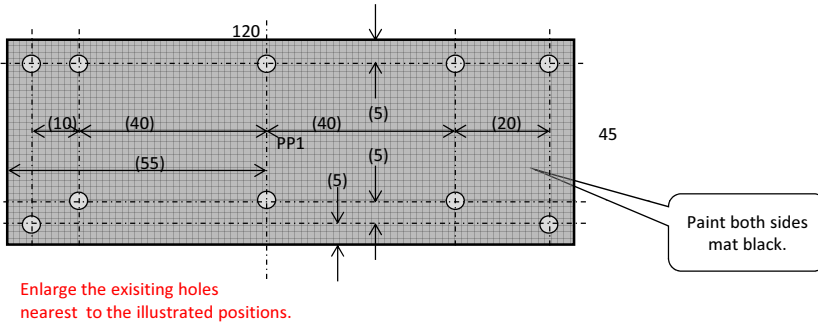

PP2: Top perforated panel R

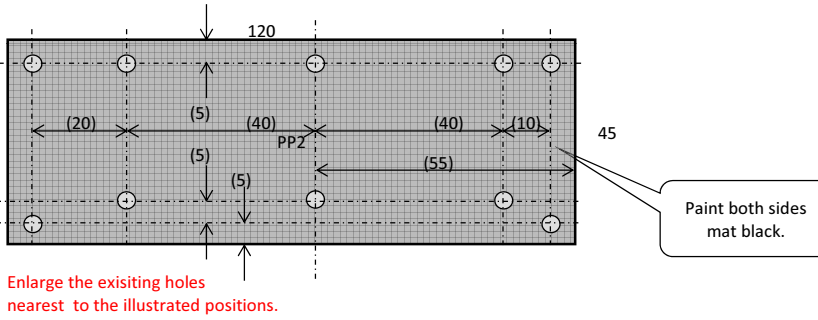

PP3: Side perforated panel L

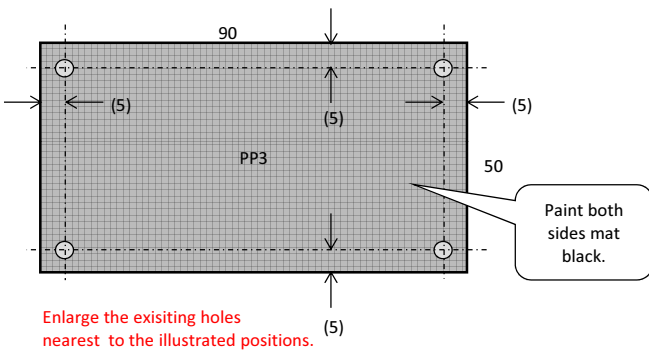

PP4: Side perforated panel R

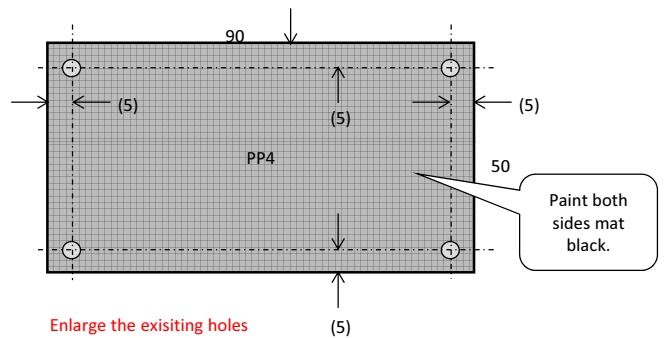

PP5: Top perforated panel PS

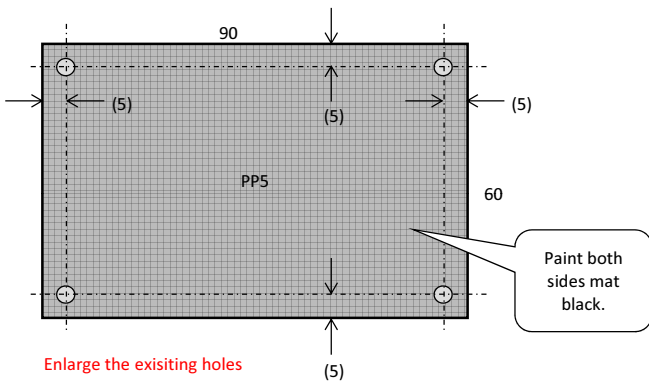

PP6: Bottom perforated panel PS

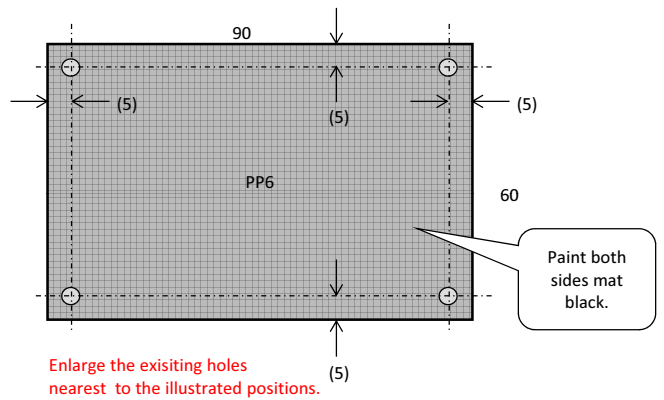

Channels

Procedure

1. Cut out the channels from the standard size channel.
2. Make mark-off lines.
3. Mark the centers of the holes with a center punch.
4. Drill the holes.
5. Tap the threads.

Aluminum channel 2.0t 40x20x1000mm for CH1, CH2, CH3 and CH4 (Scale: 1/4)

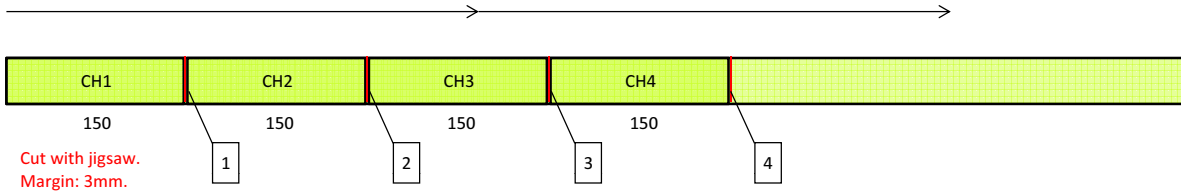

CH1: Side channel L1

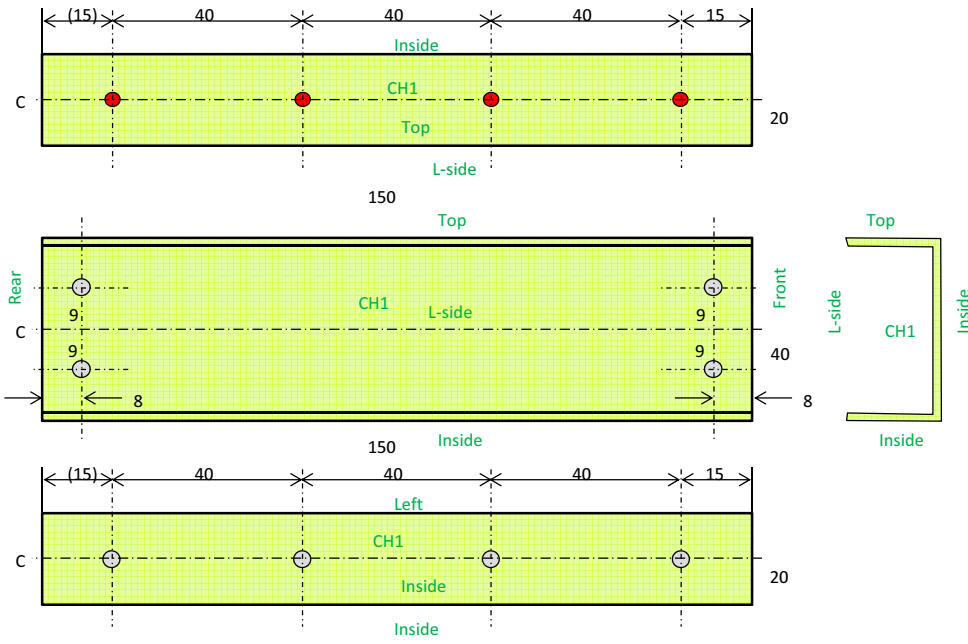

CH2: Side channel L2

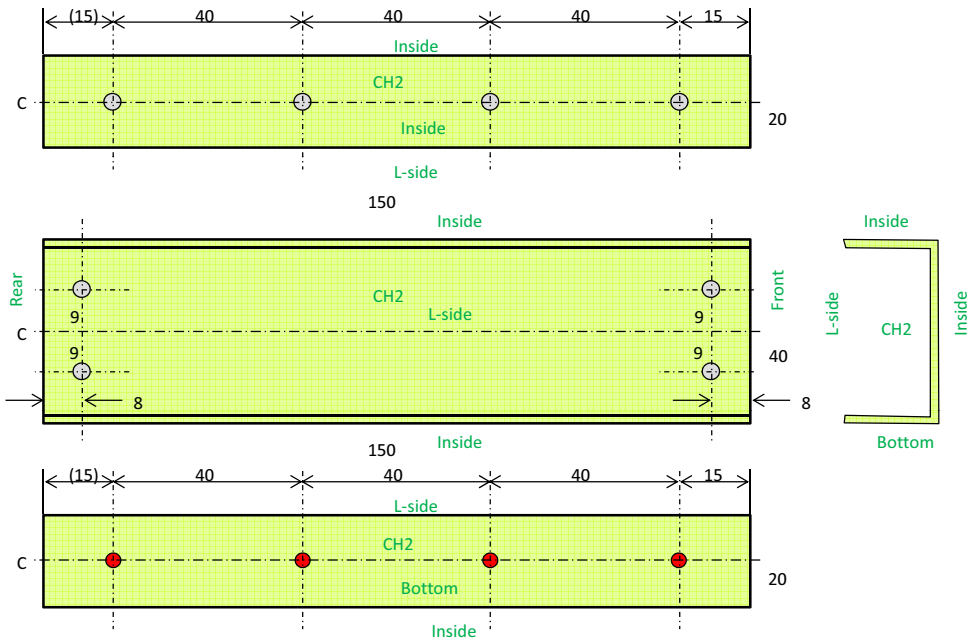

CH3: Side channel R1

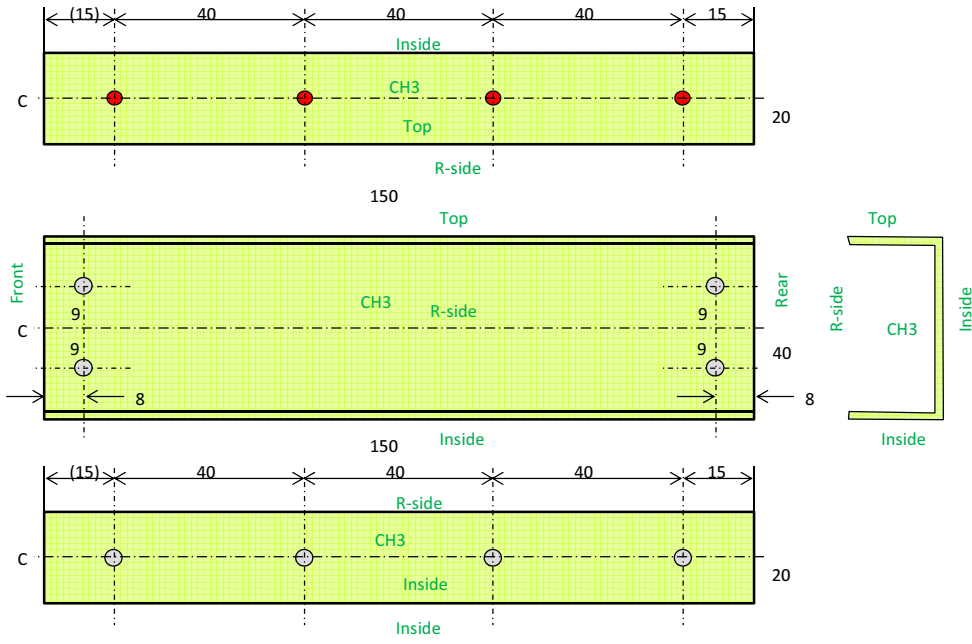

CH4: Side channel R2

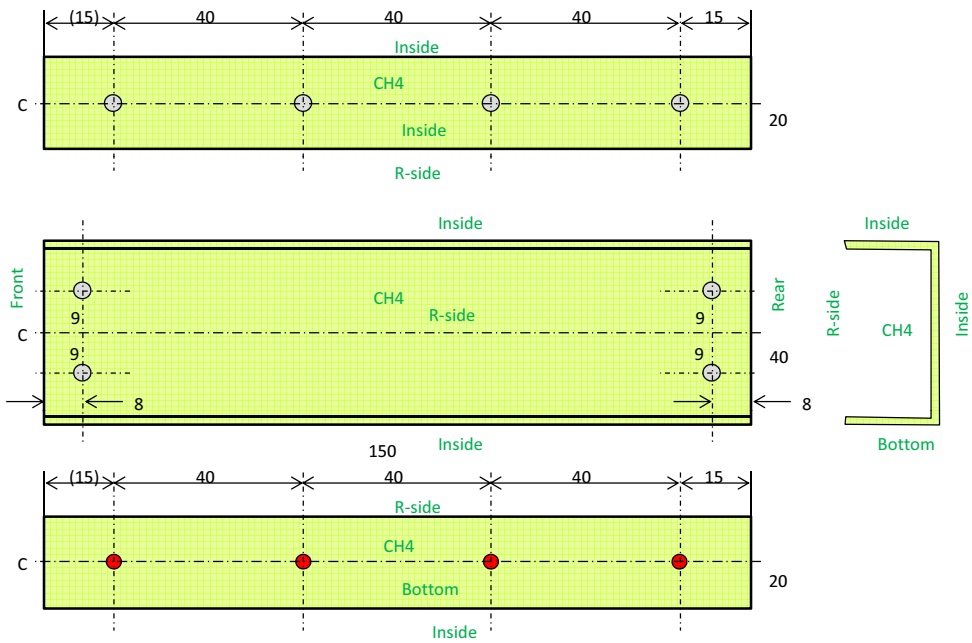

Aluminum channel 2.0t 15x15x1000mm for CH5 and CH6 (Scale: 1/4)

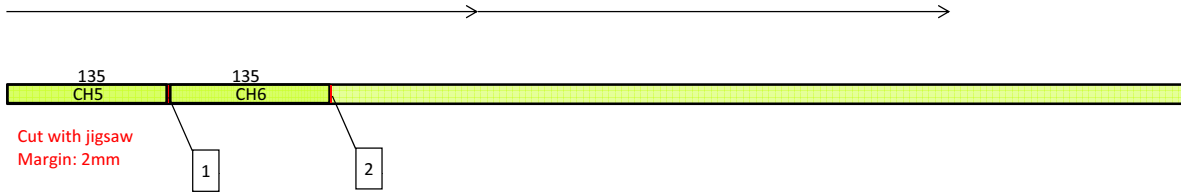

CH5: Transformer channel F

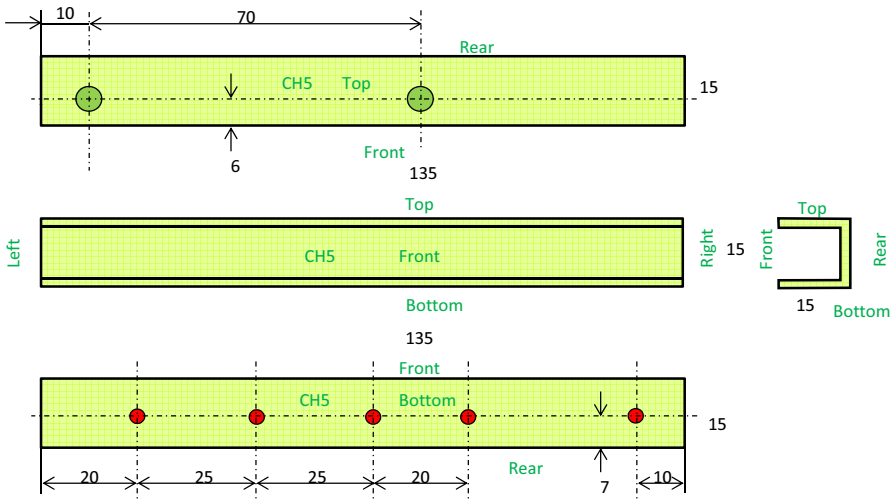

CH6: Transformer channel R

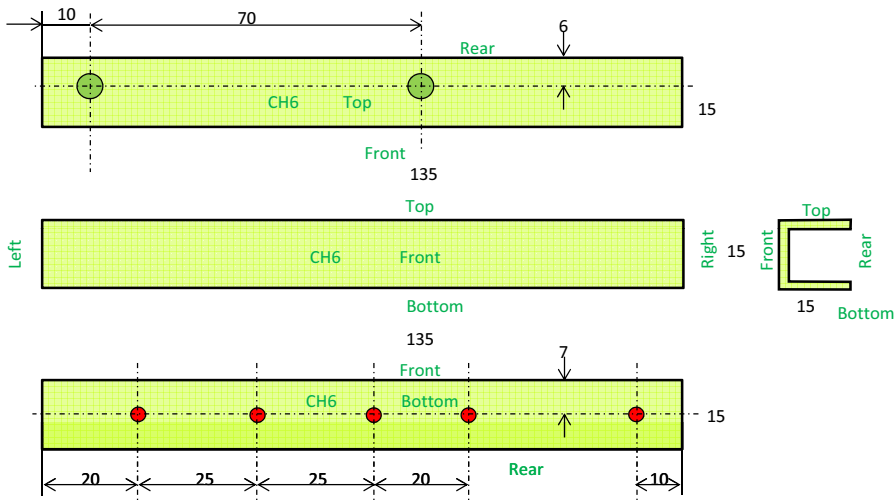

L-angles

Procedure

1. Draw the mark-off lines on the standard size L-angle with mark-off needle.
2. Make holes with drill.
3. Make threads with screw tap.
4. Cut each L-angle from the standard size L-angle.

A1: Front panel angle L1

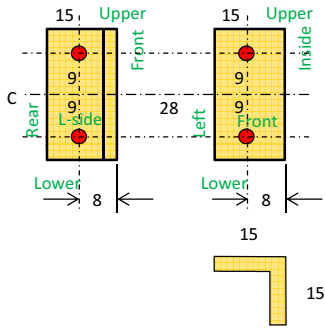

3.0t 15x15x300mm L-angle

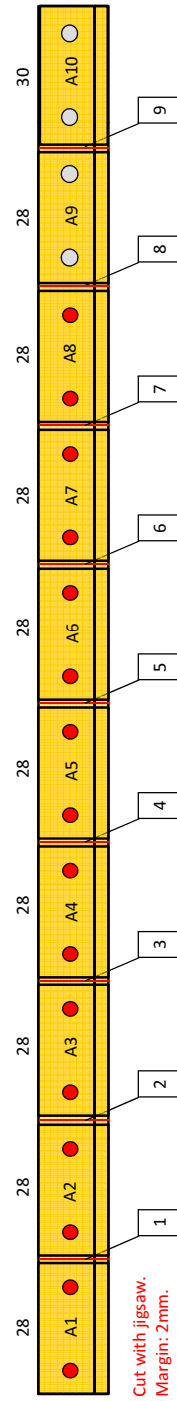

A2: Front panel angle L2, A3: Front panel angle R1, A4: Front panel angle R2

Same as A1

A5: Rear panel angle R1, A6: Rear panel angle R2, A7: Rear panel angle L1, A8: Rear panel angle L2

Same as A1

A9: Top panel angle R

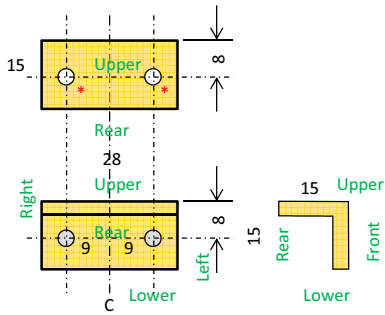

*: Phi 3.2 ==> M4 thread

A10: Top panel angle L

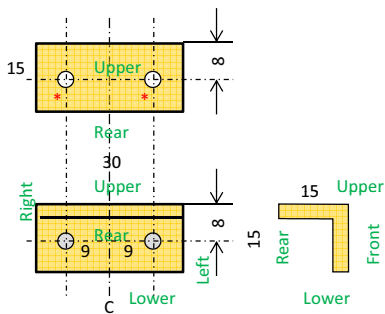

*: Phi 3.2 ==> M4 thread

Bars

Procedure

1. Draw the mark-off lines on the standard size bar with mark-off needle.
2. Cut each bar from the standard size bar.
3. Drill the holes.
4. Tap threads.

Aluminum Square bar 8x8x1000mm (Scale: 1/4)

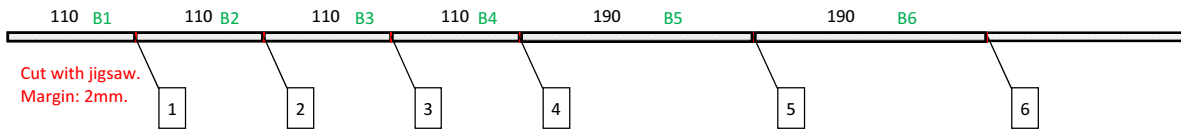

B1: Square bar L-top

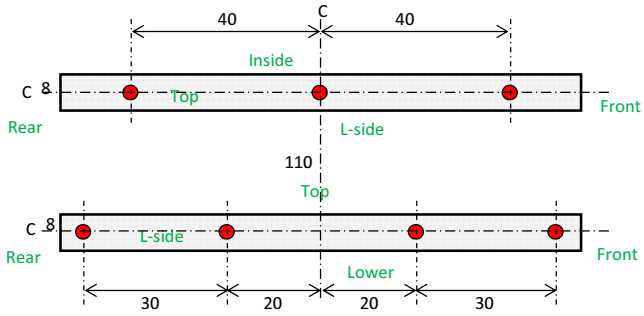

B2: Square bar L-bottom, B3: Square bar R-top, B4: Square bar R-bottom

Same as B1

B5: Square bar Top

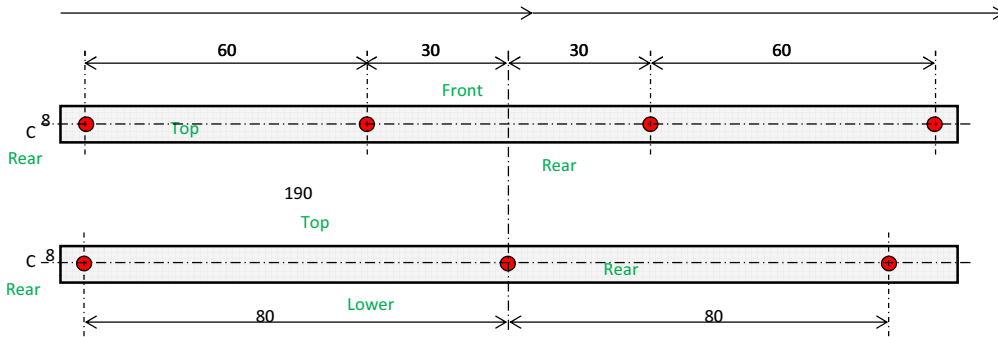

B6: Square bar Bottom

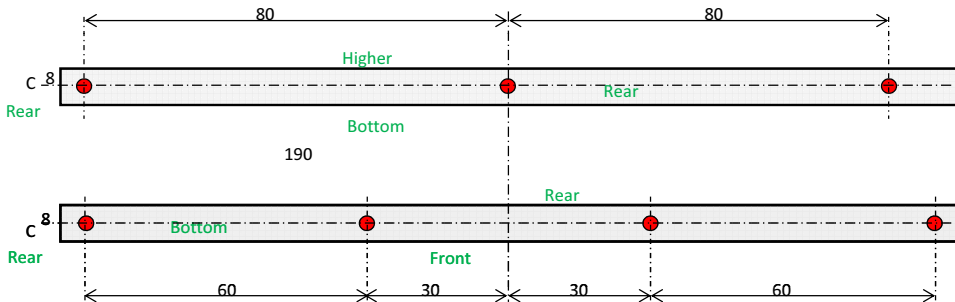

End of the drawing