

Woodwork

Edge rounding and cutout

2017/02/09

Revised: 2017/06/03

- Phi32 hole: (1) Drill 4MM hole; (2) Drill 6.5MM; (3) Drill 32MM with circle saw (attachment of power drill) halfway; (4) Drill 32MM from the lower side and penetrate.

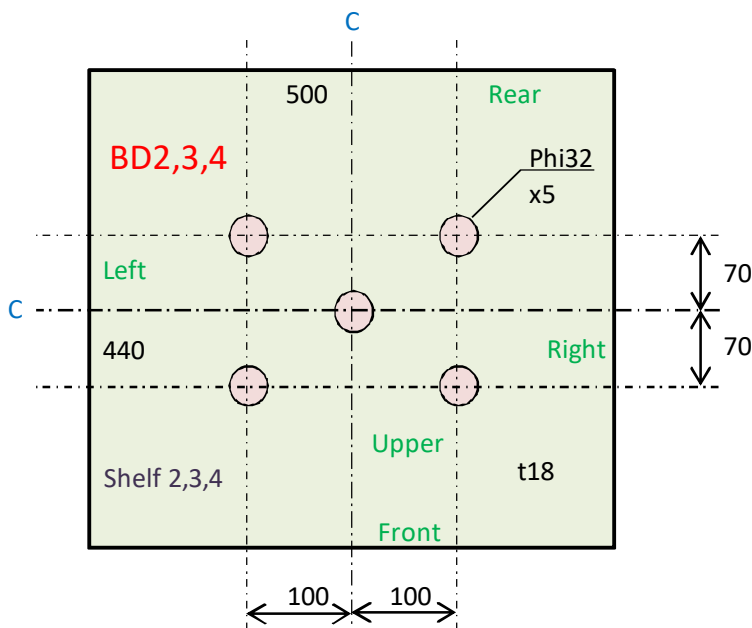
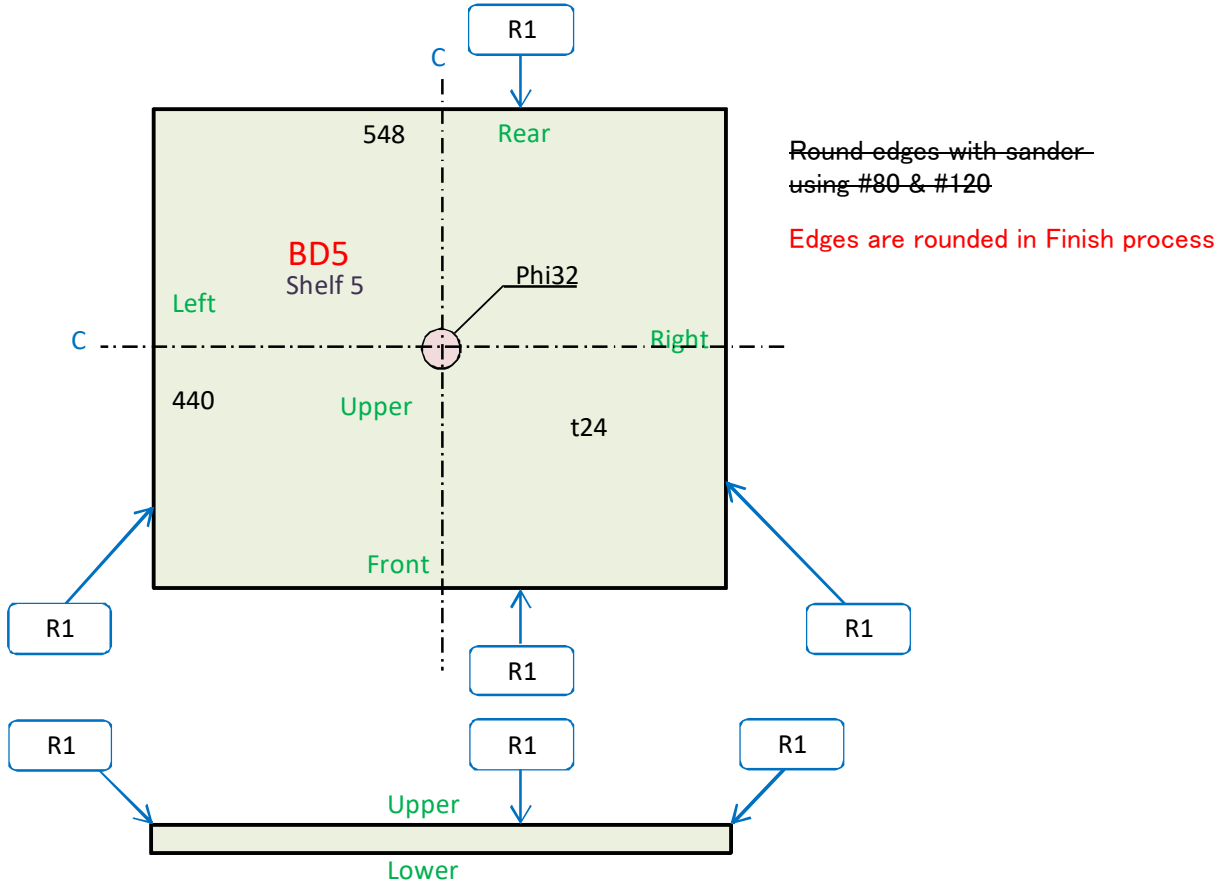

- Phi32 hole: (1) Drill 4MM hole; (2) Drill 6.5MM; (3) Drill 32MM with circle saw (attachment of power drill) halfway; (4) Drill 32MM from the lower side and penetrate.

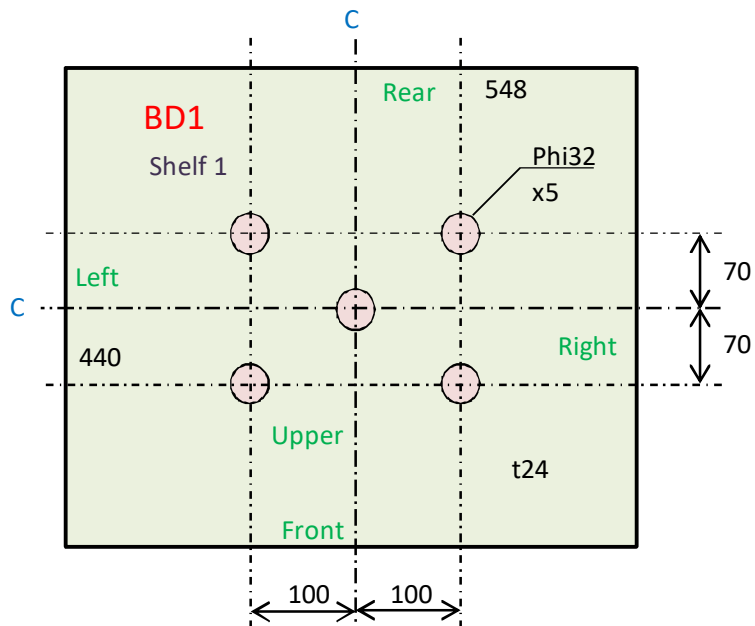

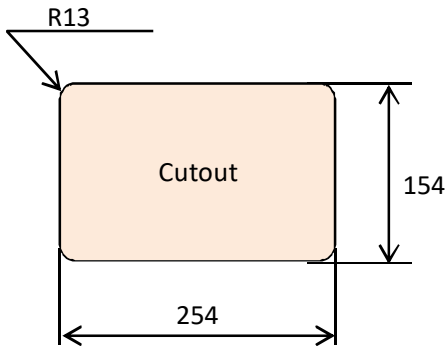

Cutouts are made in Assembly process

- Phi23 hole: (1) Drill 4MM hole; (2) Drill 6.5MM;
- (3) Drill 26MM with circle saw (attachment of power drill) halfway; (4) Drill 26MM from the outer side and penetrate.

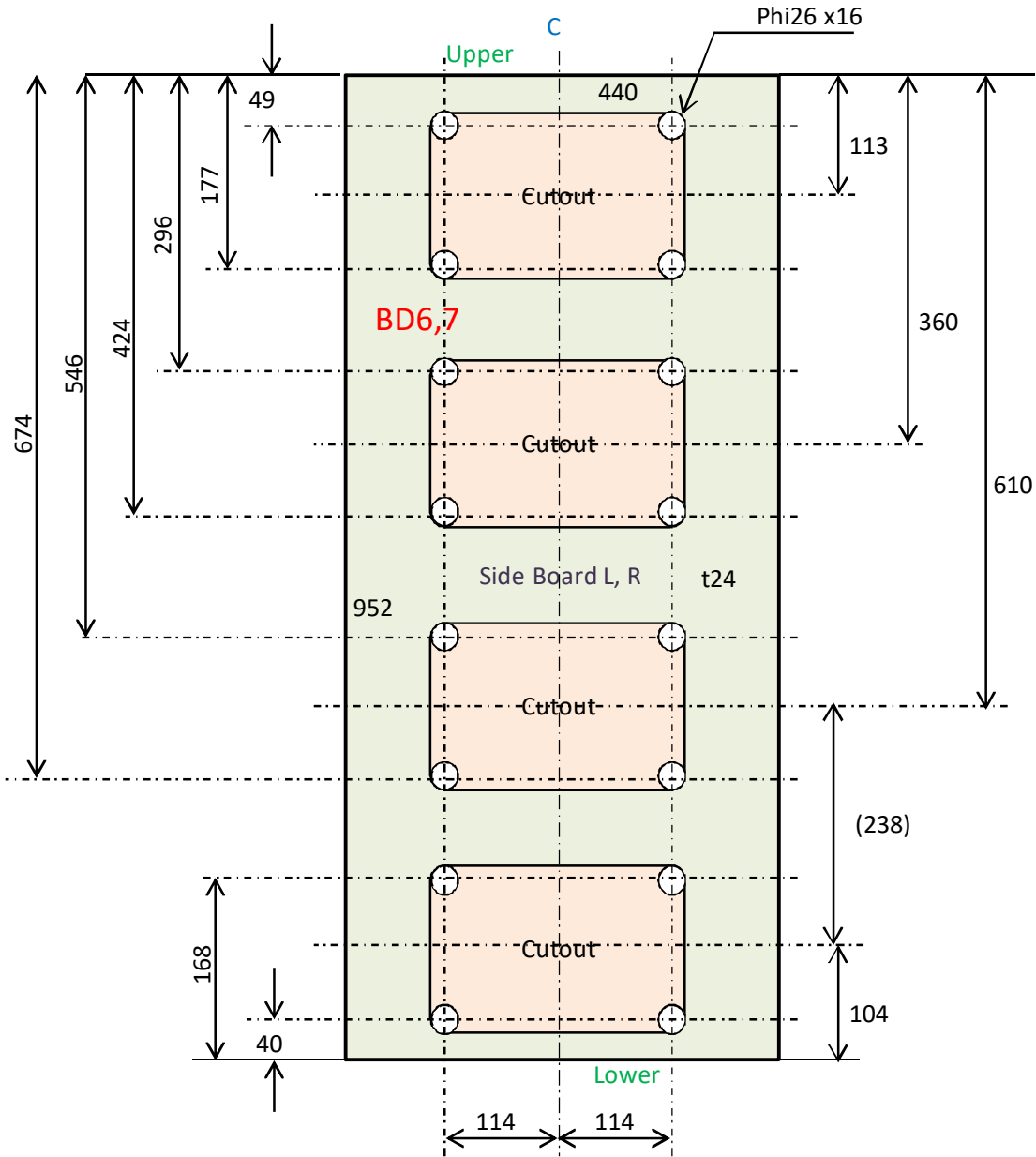

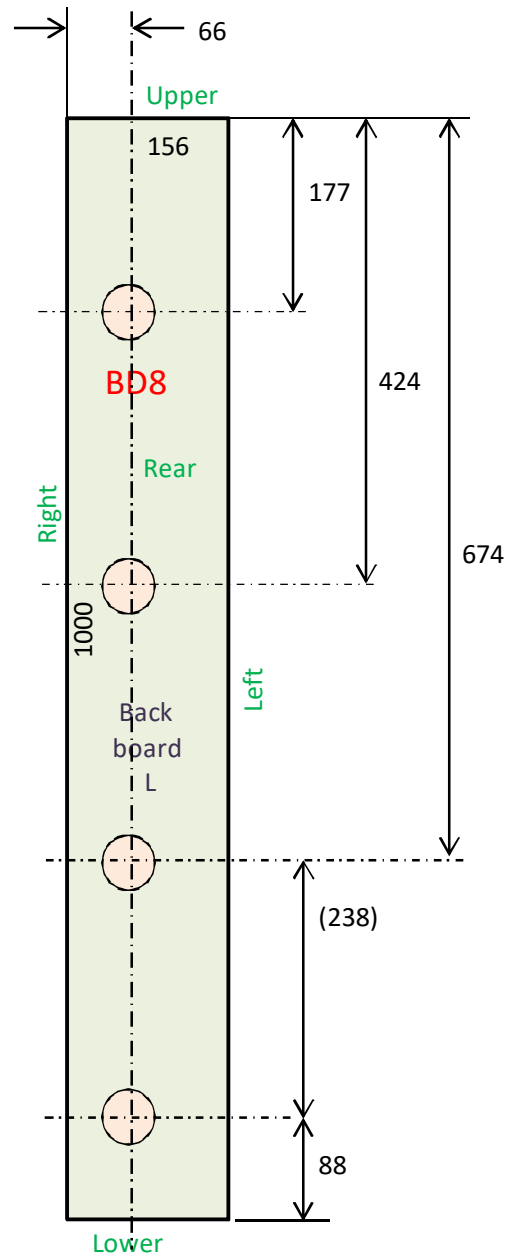
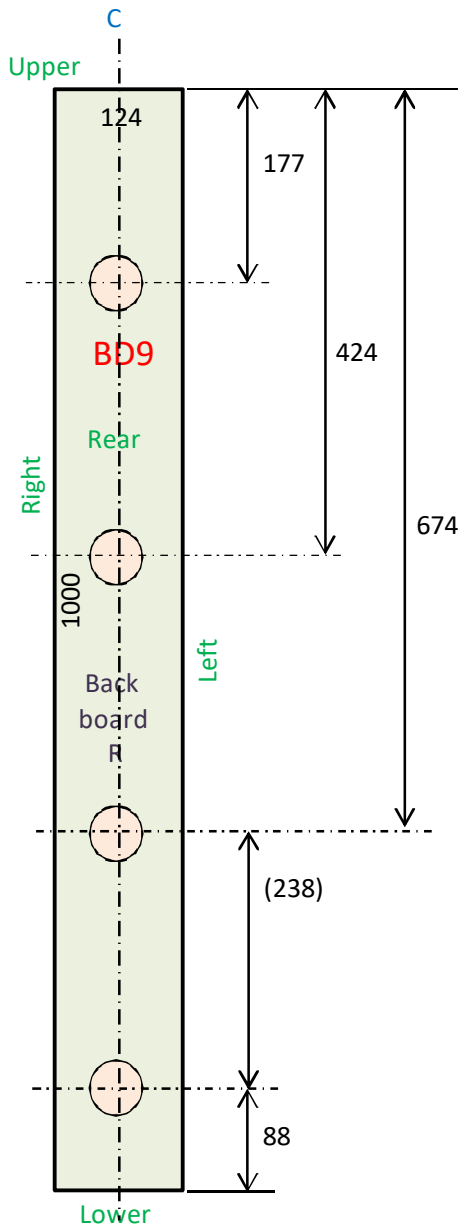
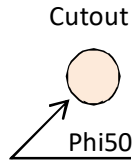

Screw holes

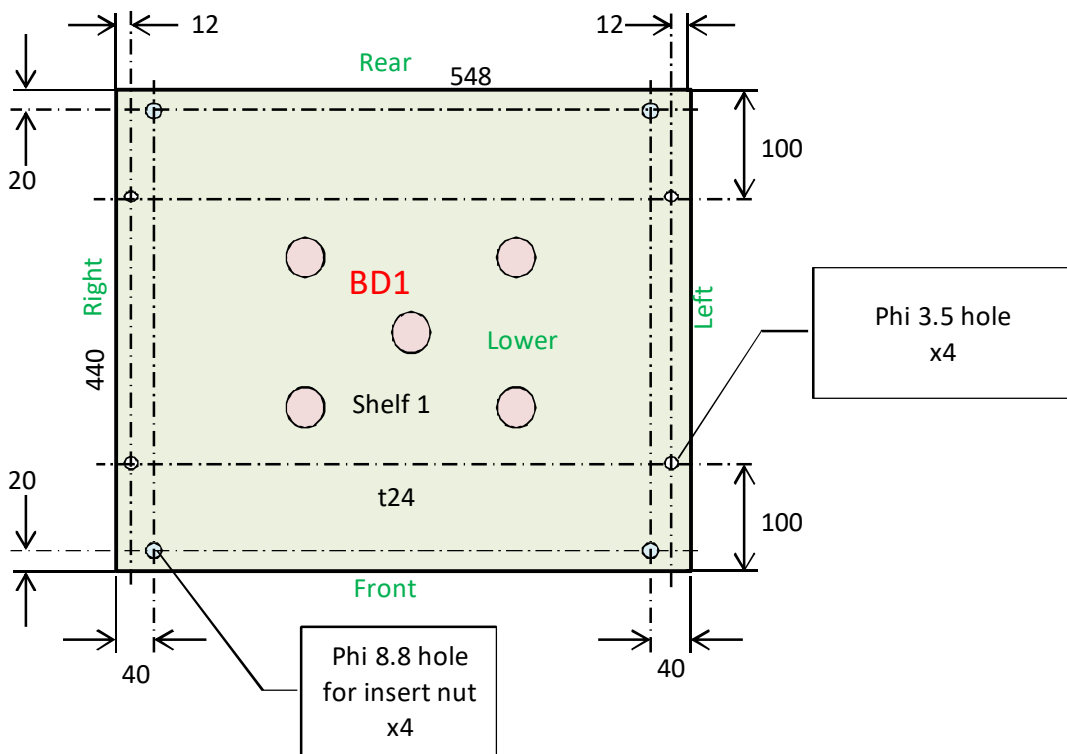
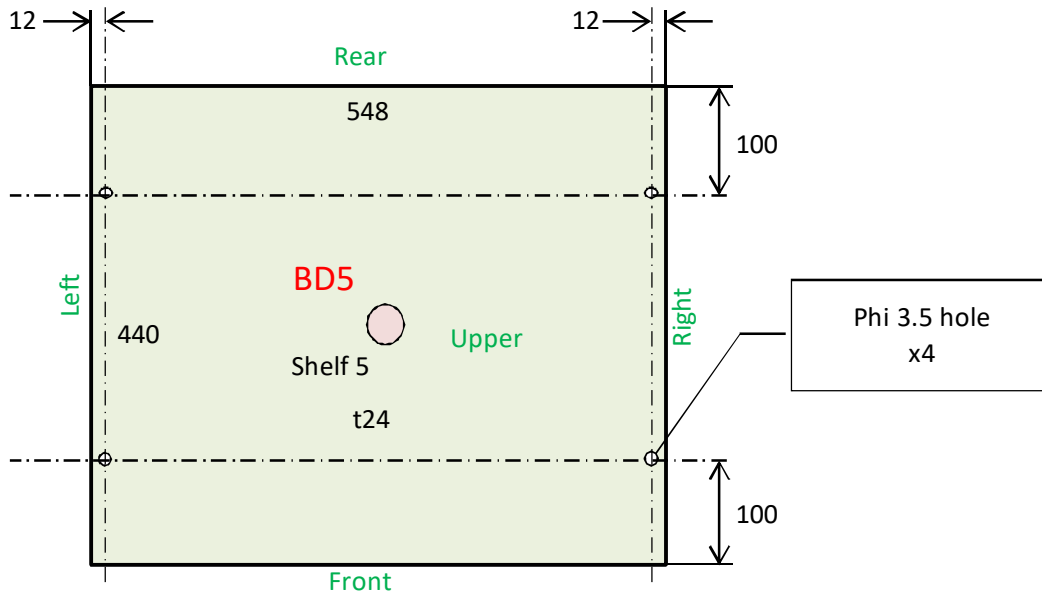

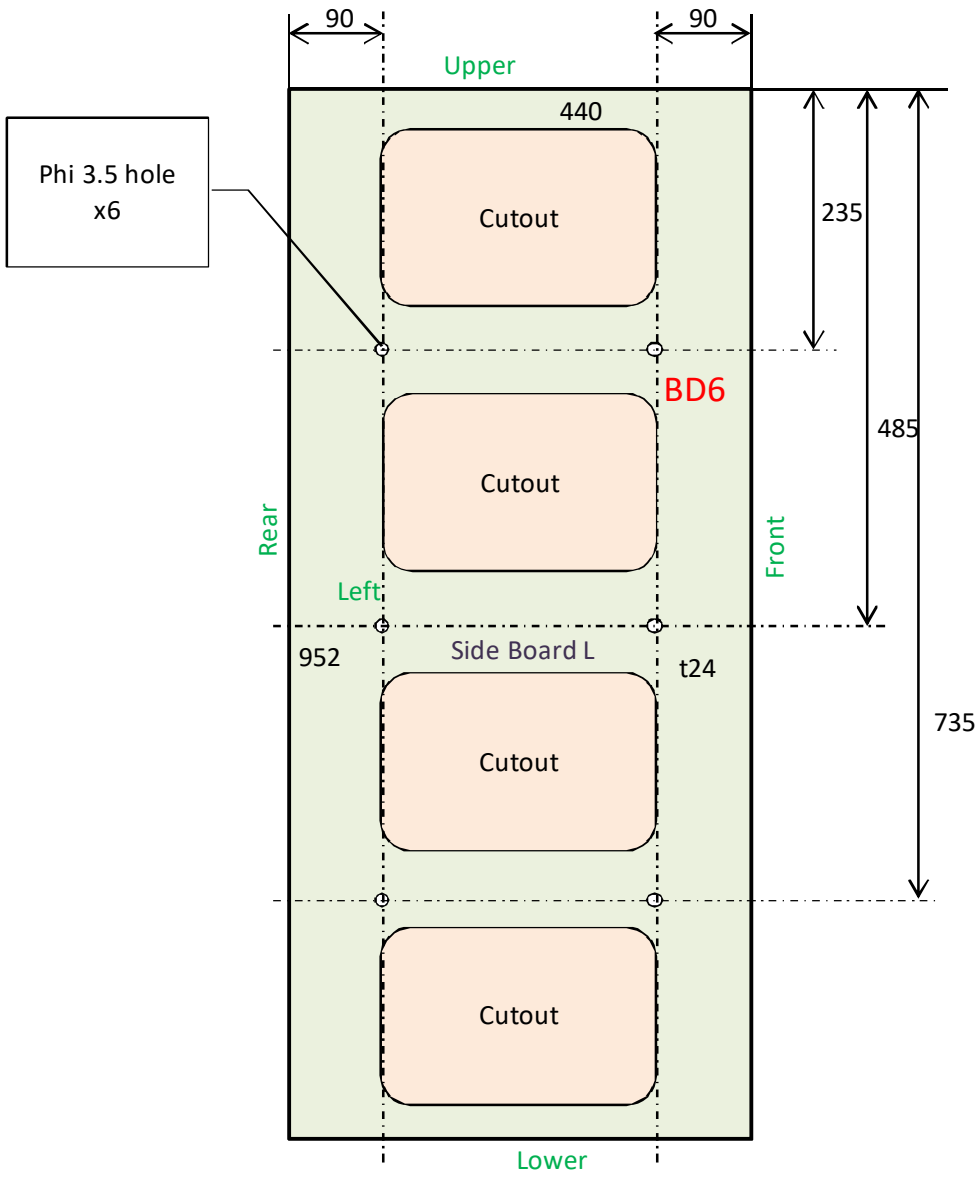

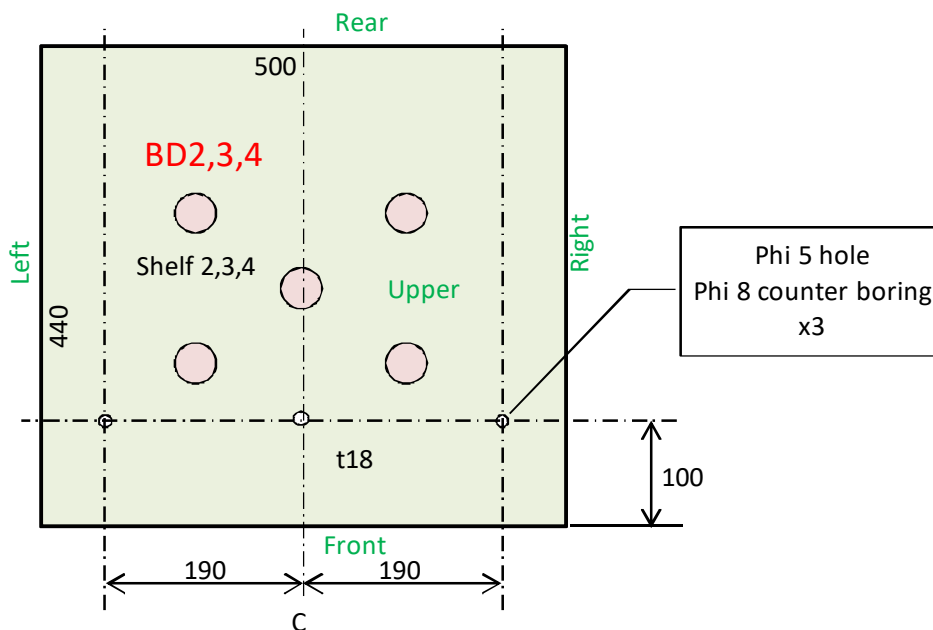
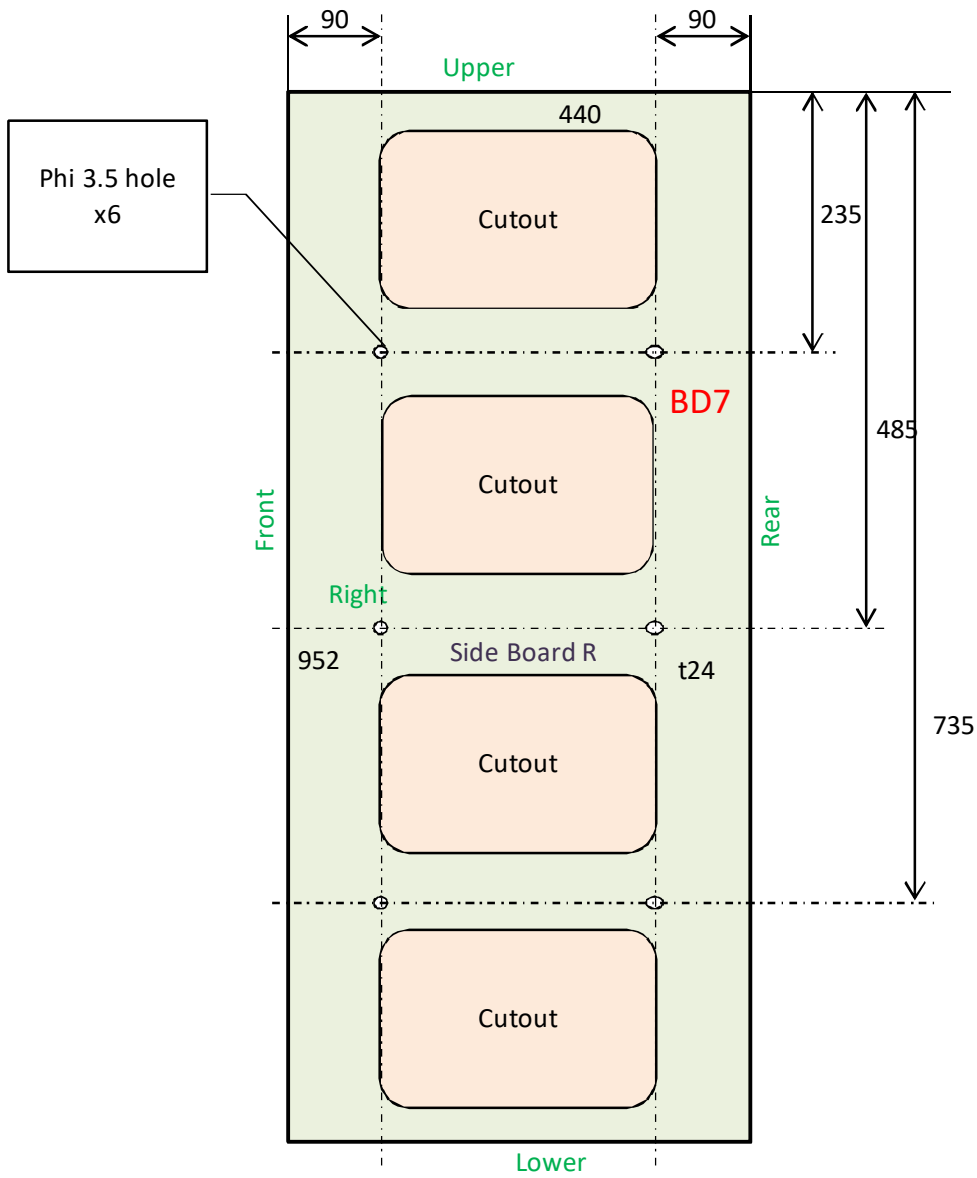

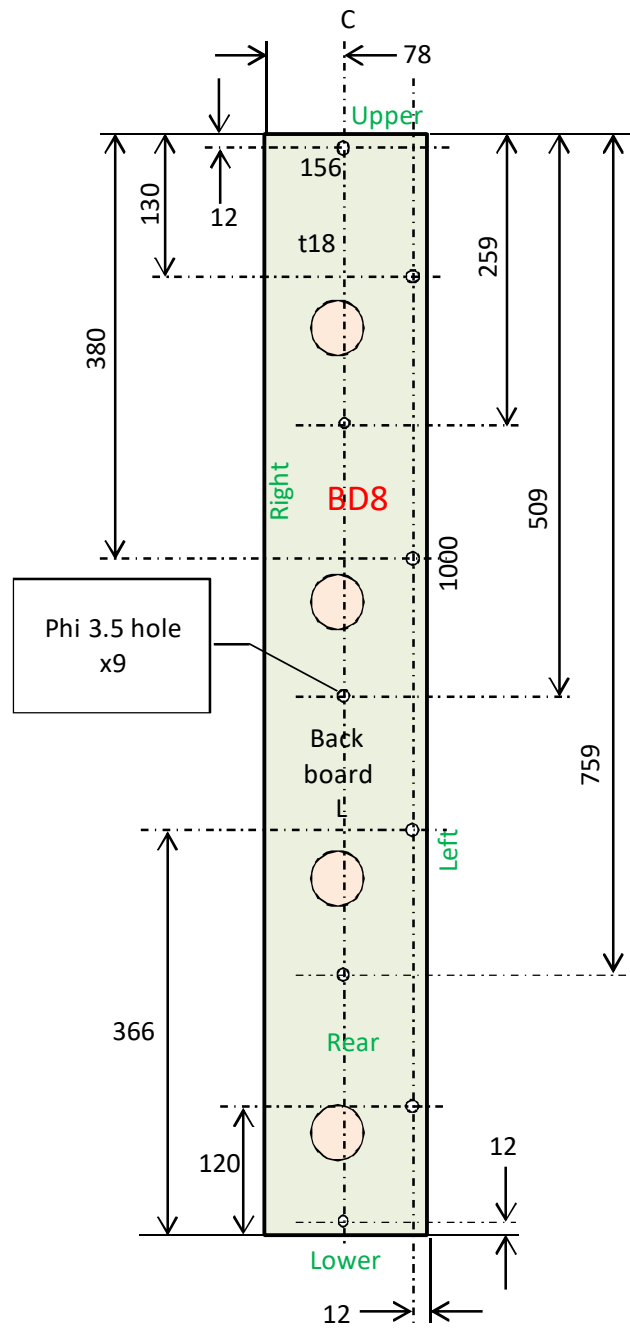
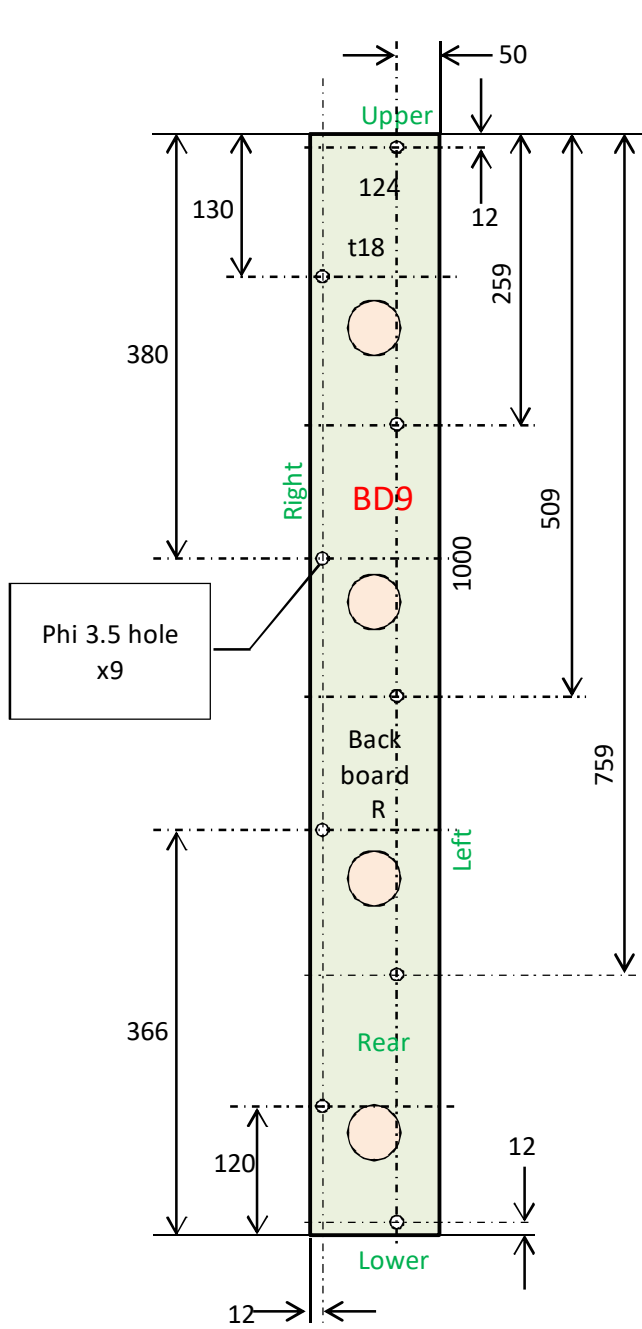

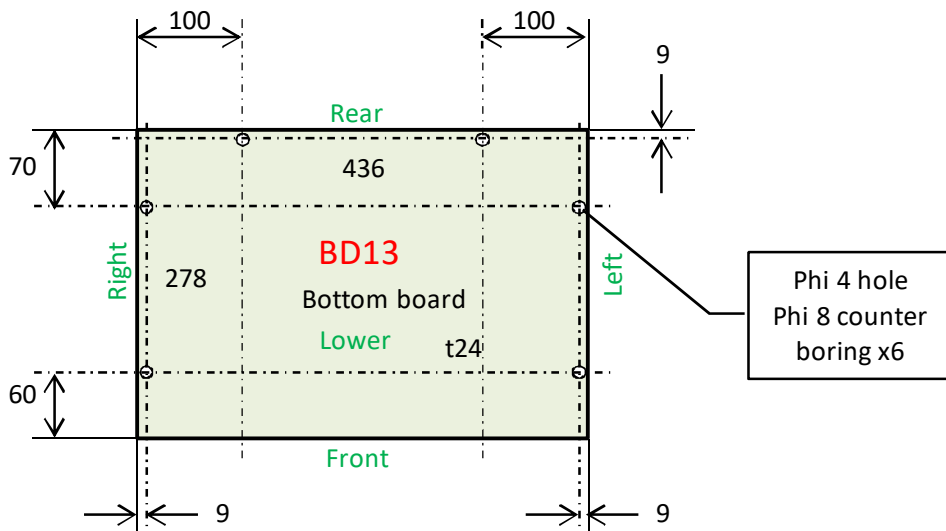
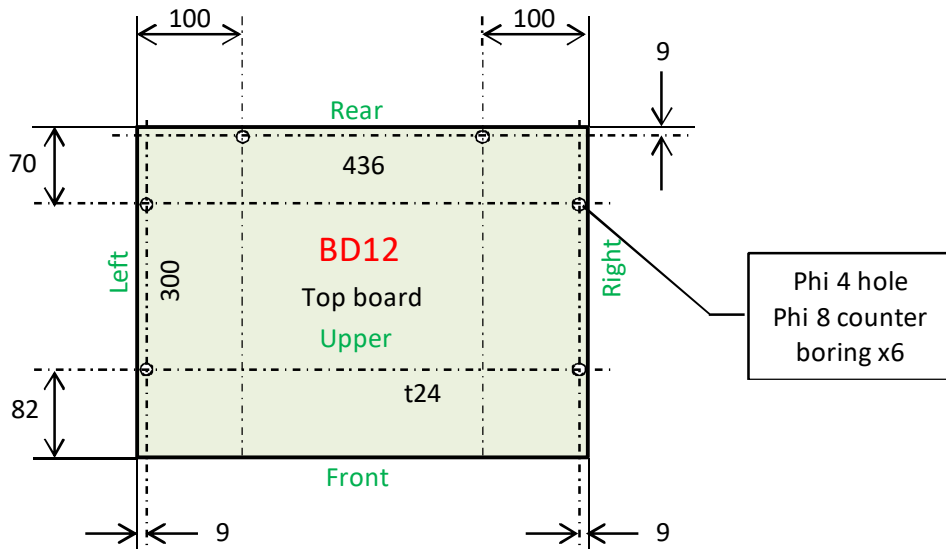

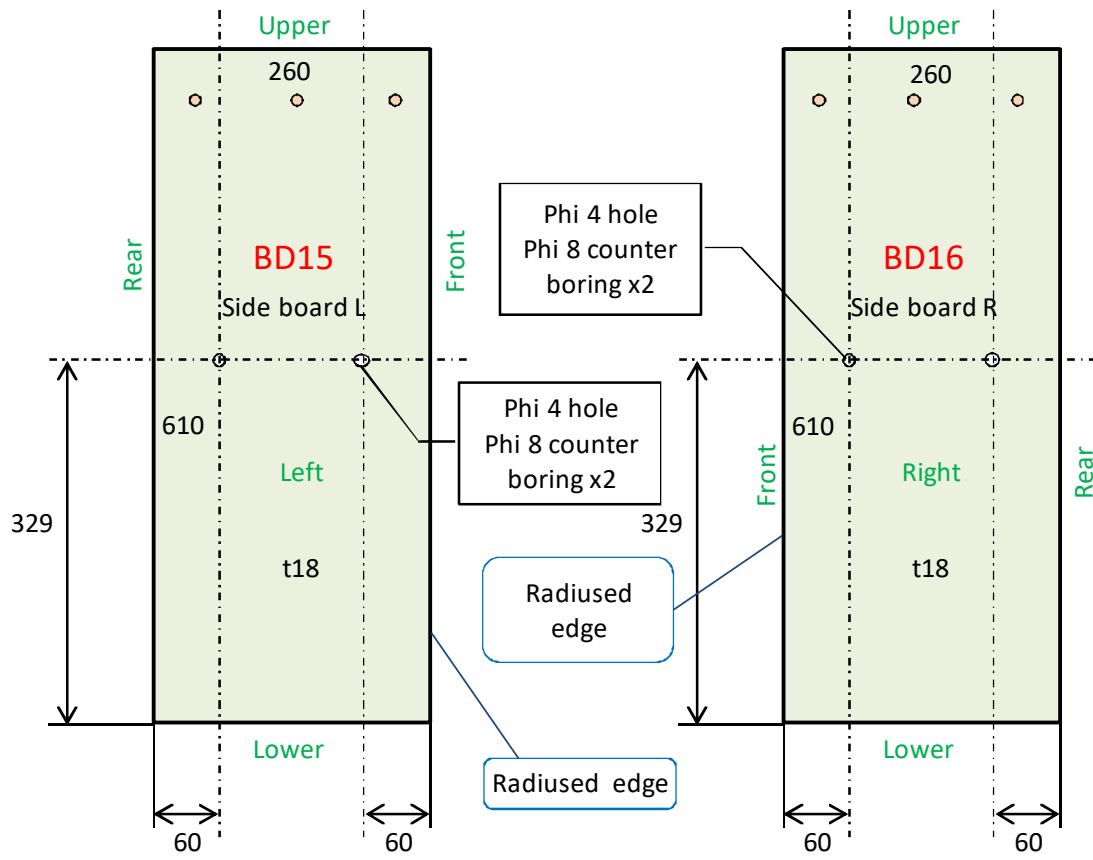

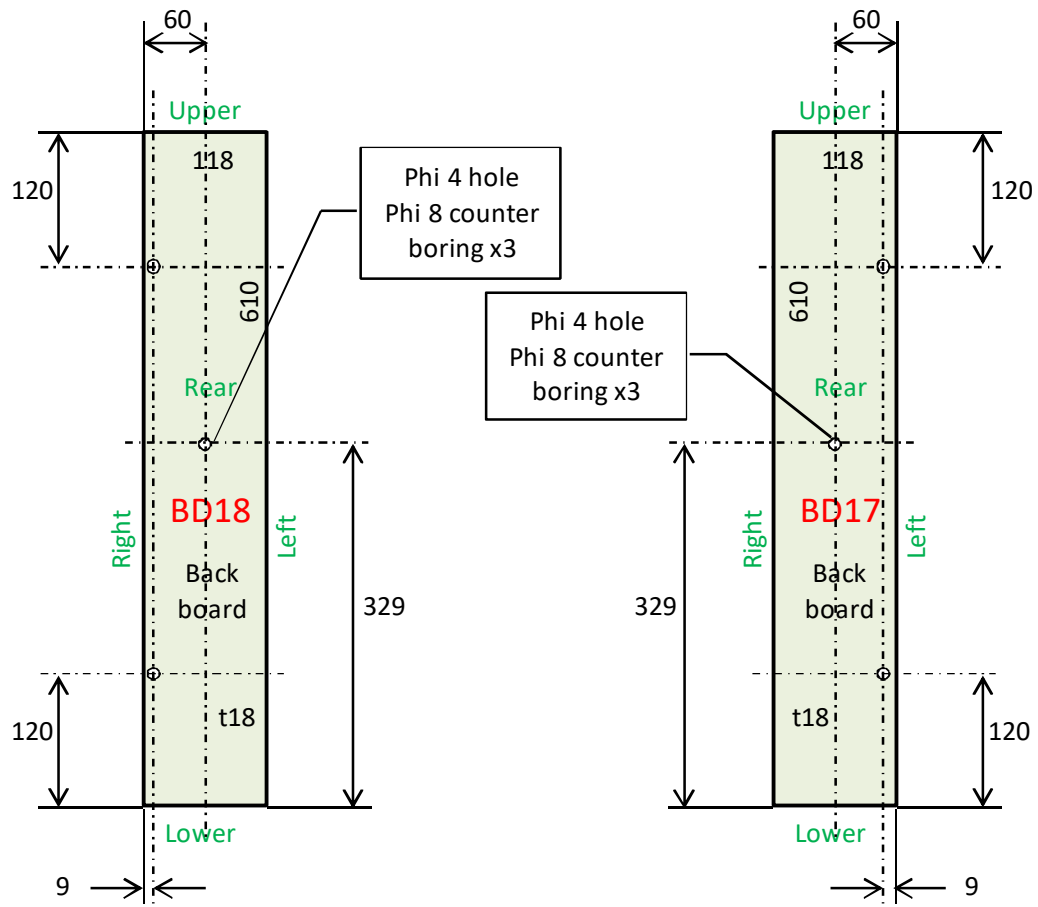

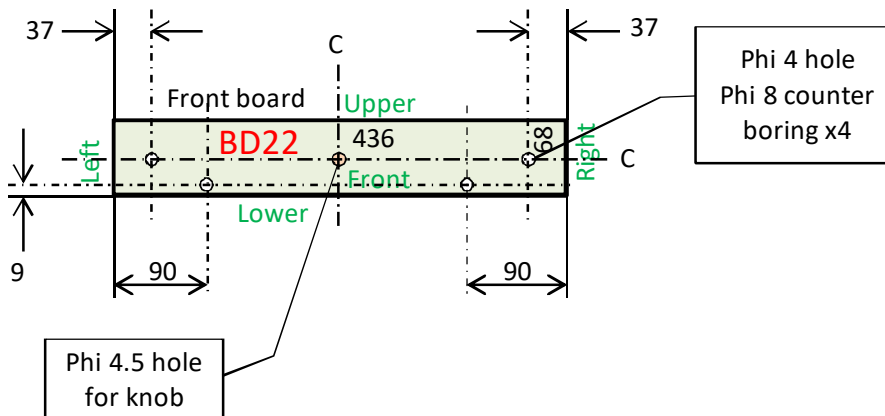
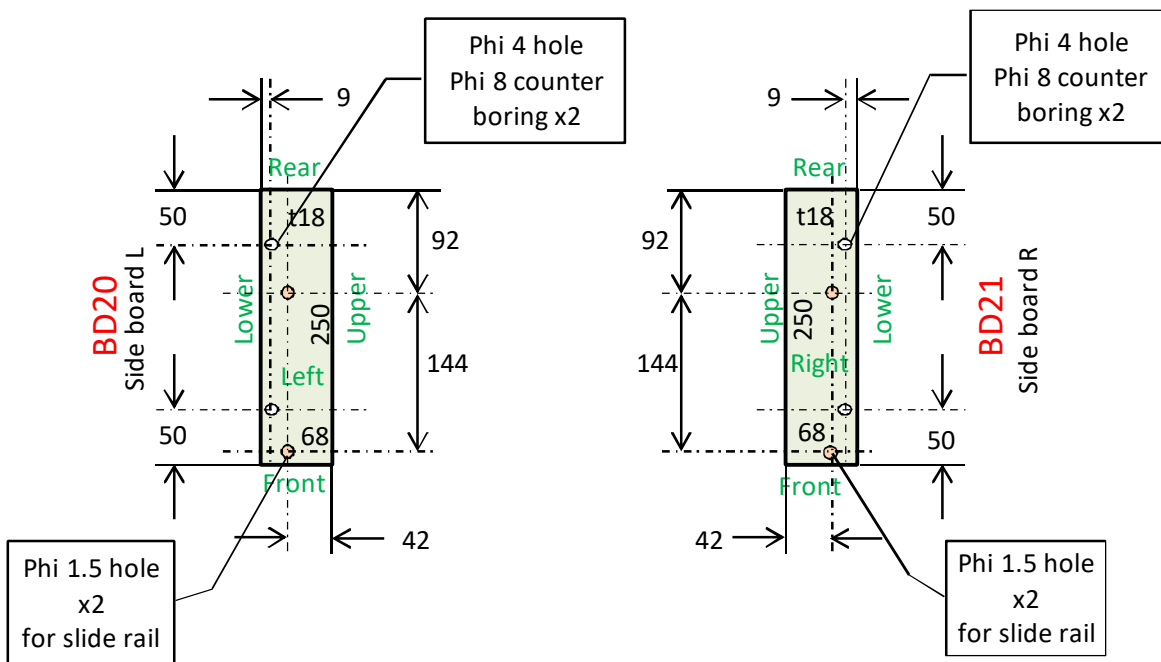
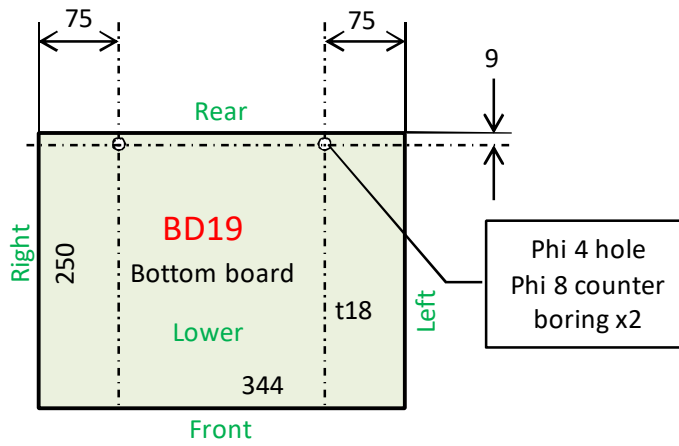

[End of Sheet]

Edge rounding

This process is to be done after assembling.

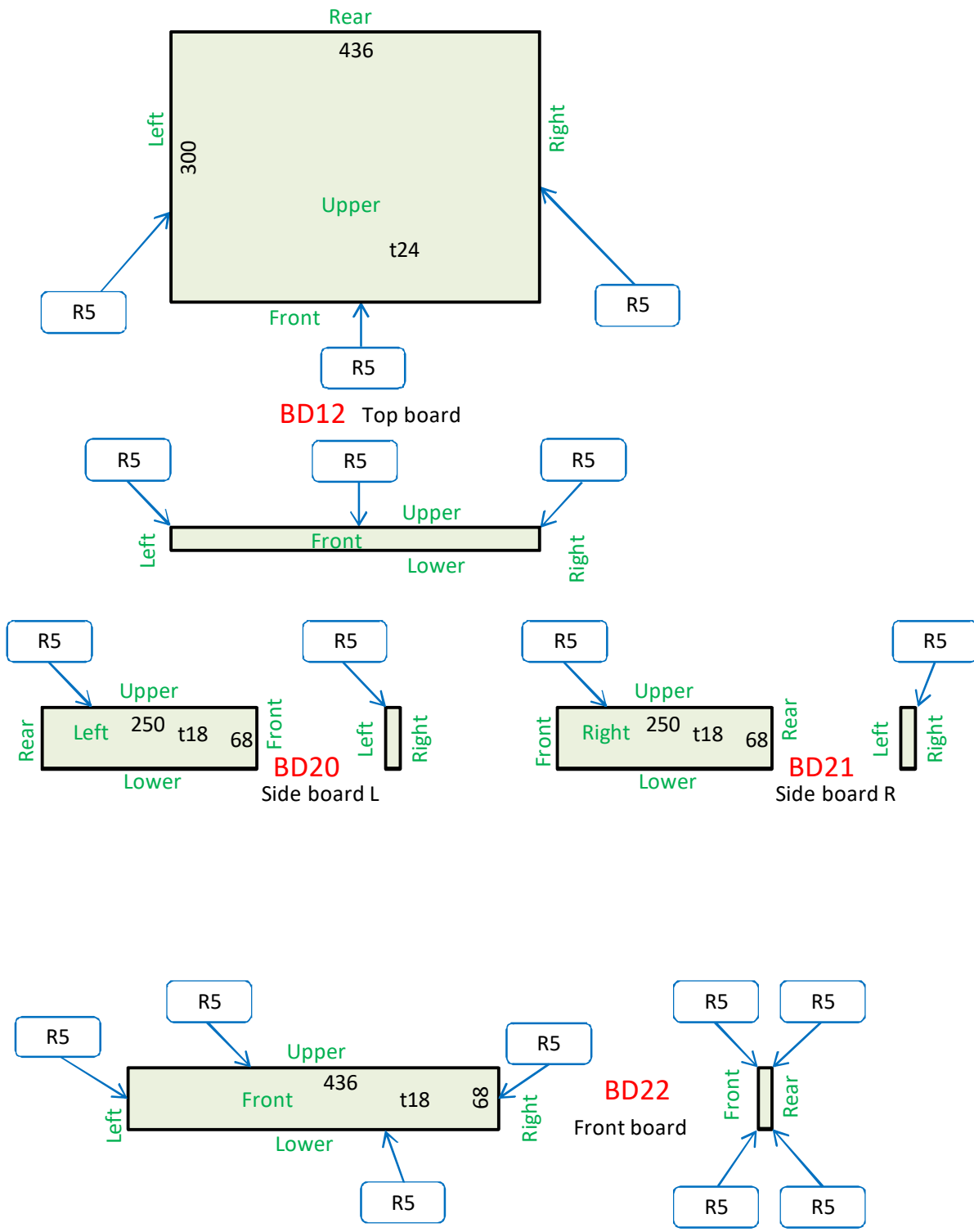

Carpet / cork sheet

AR-416

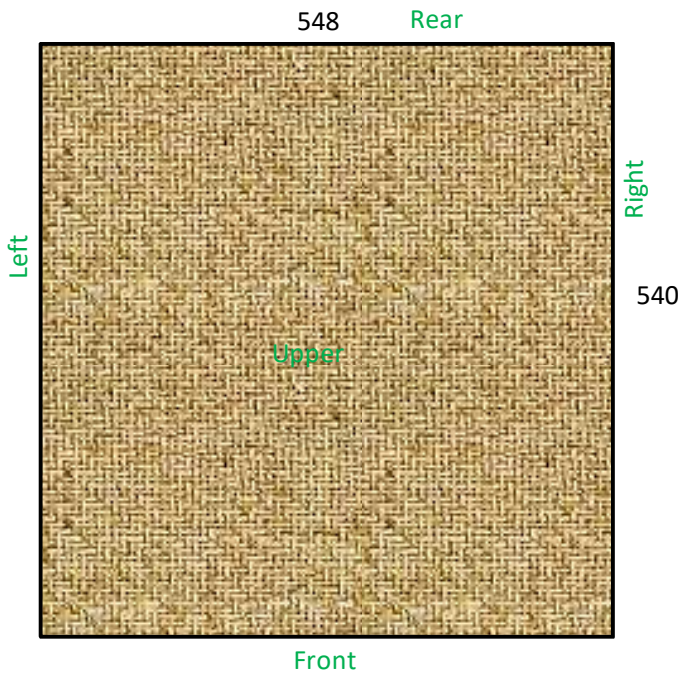

Carpet to be affixed under bottom board BD10

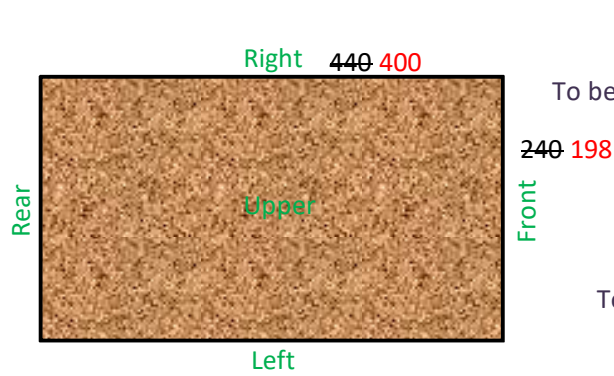

Cork sheet
x2
To be affixed on shelf BD5 BD11,11'

Cork sheet
x12
To be affixed on small graphite boards



MiniRack

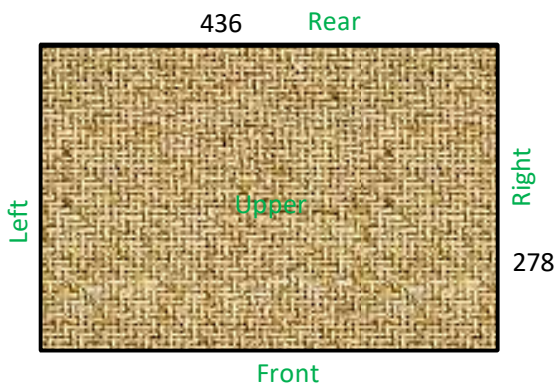

To be affixed under bottom board BD13

Sliced veneer

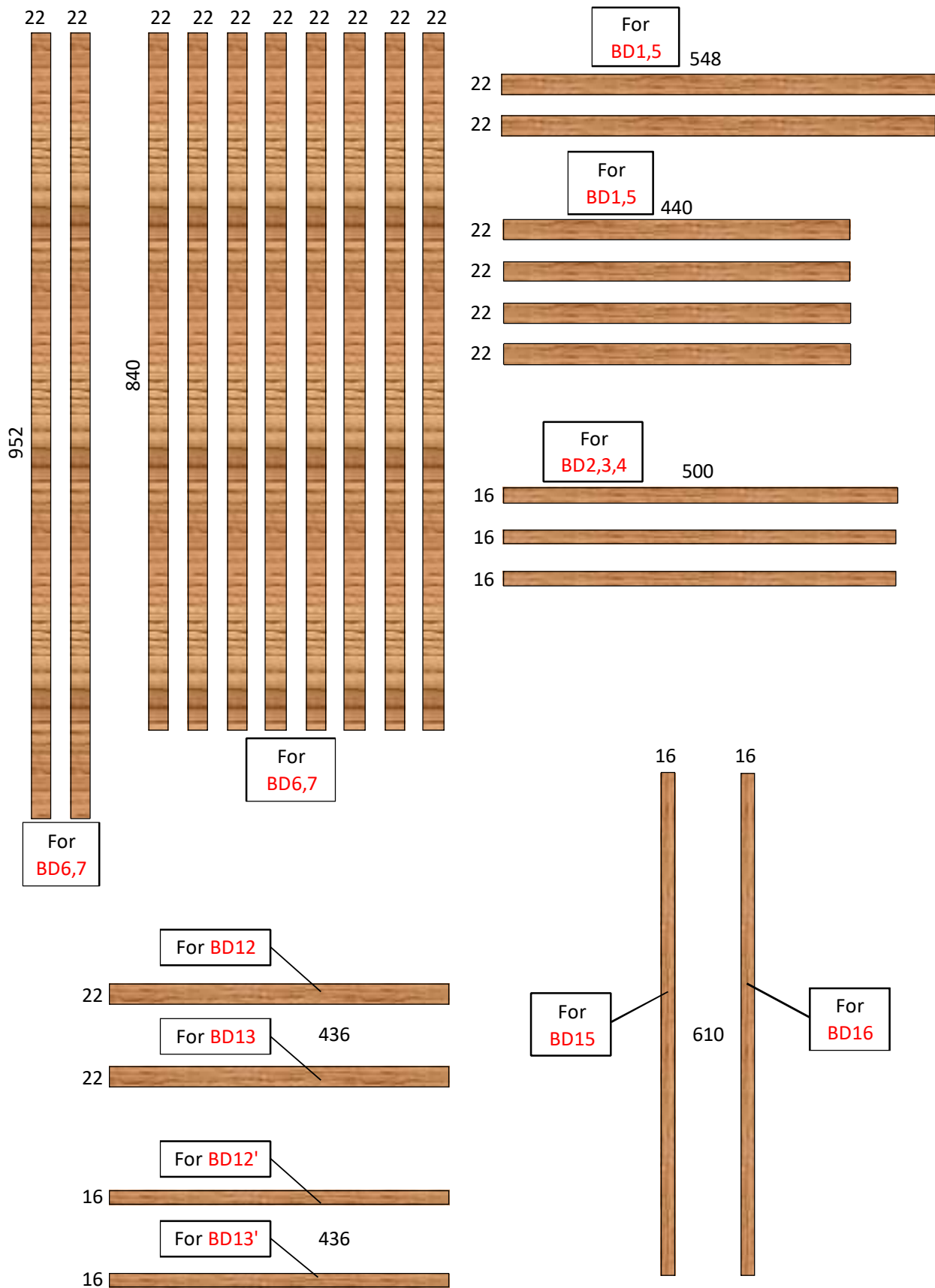

Sliced veneer layout

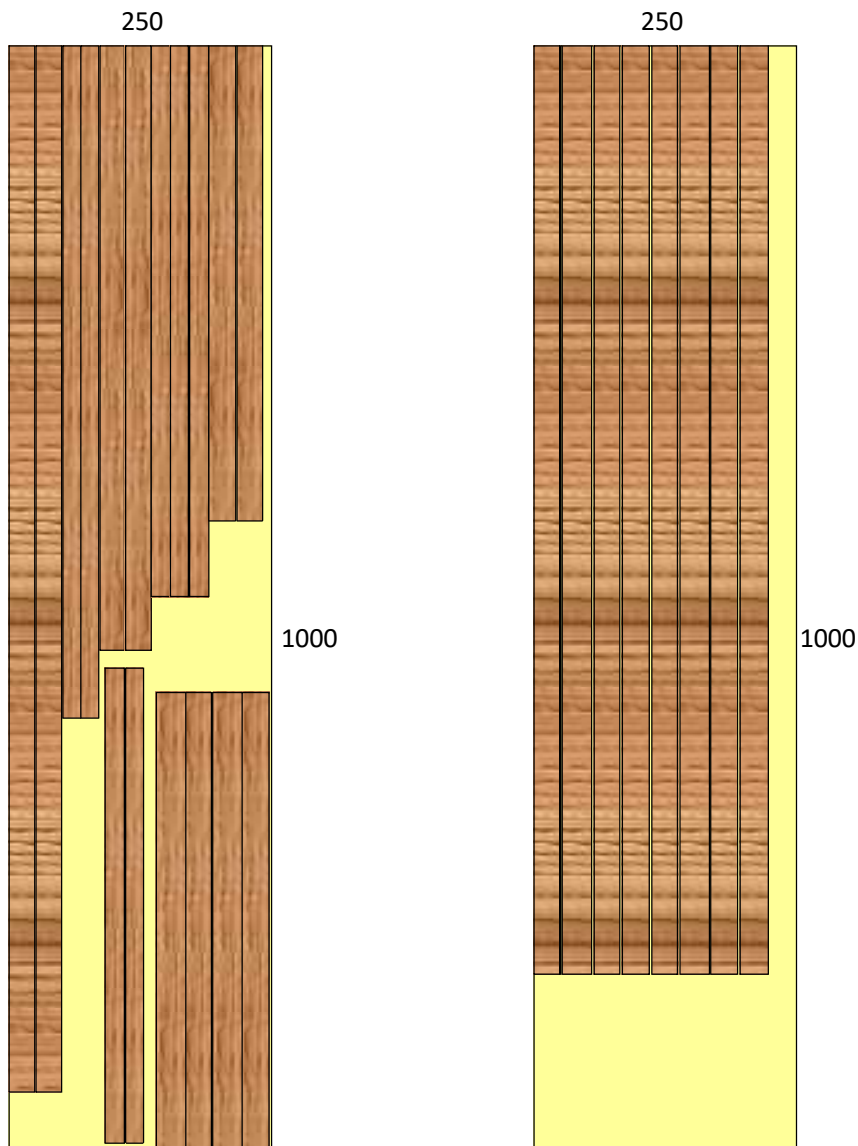

Cork sheet layout

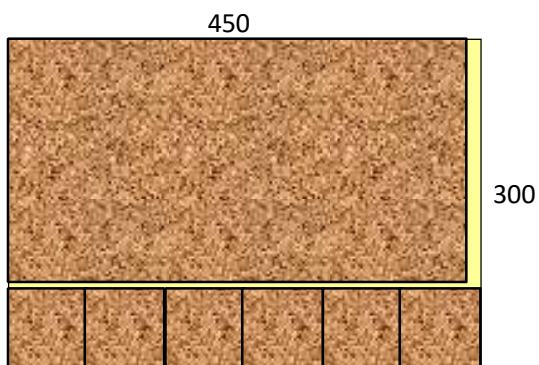

Overlap areas

