



## ***Mechanical Design***

Unlike the other projects in the past, mechanical design precedes circuit design in this project.

The looks is the top priority in this project.

In addition, the dimension of the enclosure has to be fit to ACA\_Rack, which was specially designed to accommodate DIY Audio ACA V1.6 and used in the subsystem Kinglet.

### **Overall Design**

The dimension of the enclosure is 131(W) x 172(H) x 187(D) mm (excluding the wood base and the knob).

The width is almost equal to that of the shelf of ACA\_Rack. This means EVR-3 and EVR-DISP1 can't be laid out horizontally aligned, but vertically aligned. To accommodate the volume units, the enclosure has to be tall.

The acrylic photo frame happened to be the right size to this enclosure. It is expected to make the enclosure look nice.

The acrylic panel is transparent. The sheet between the front panel and the clear panel decides the looks of the front panel. I've found one more thing: the wood knob. It looks chic.

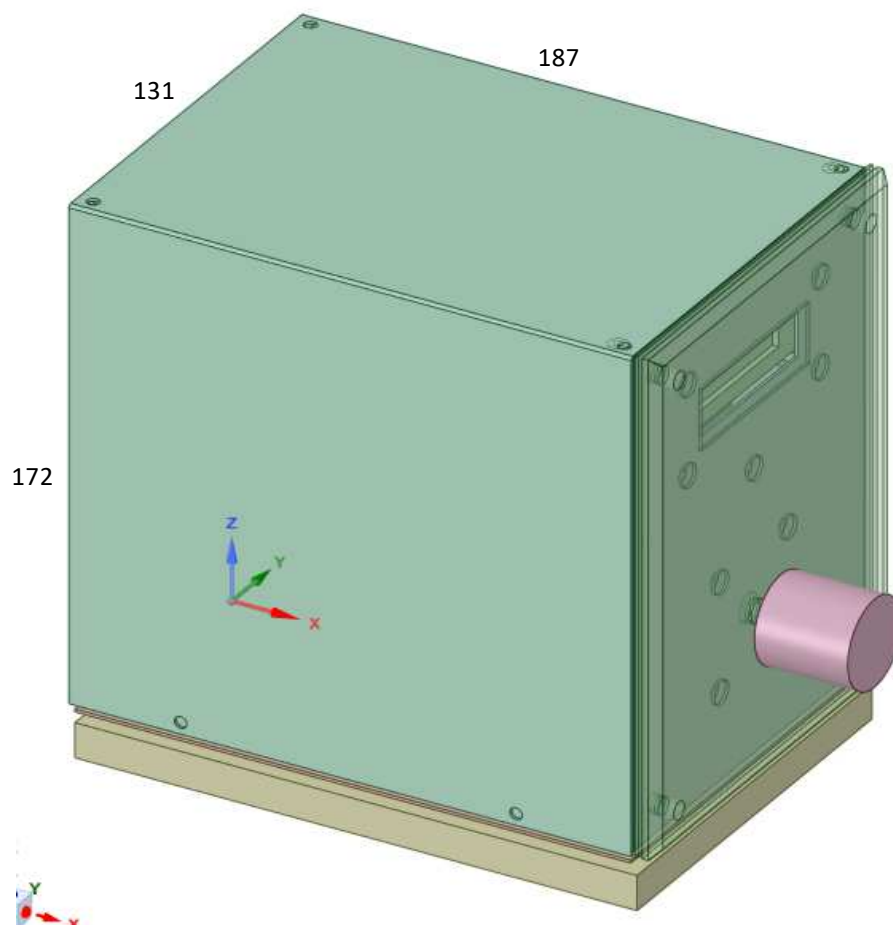

## Chassis Design

The Chassis is made by bending a single aluminum panel into horseshoe shape. In this construction minimizes impedance between the front and back panels.

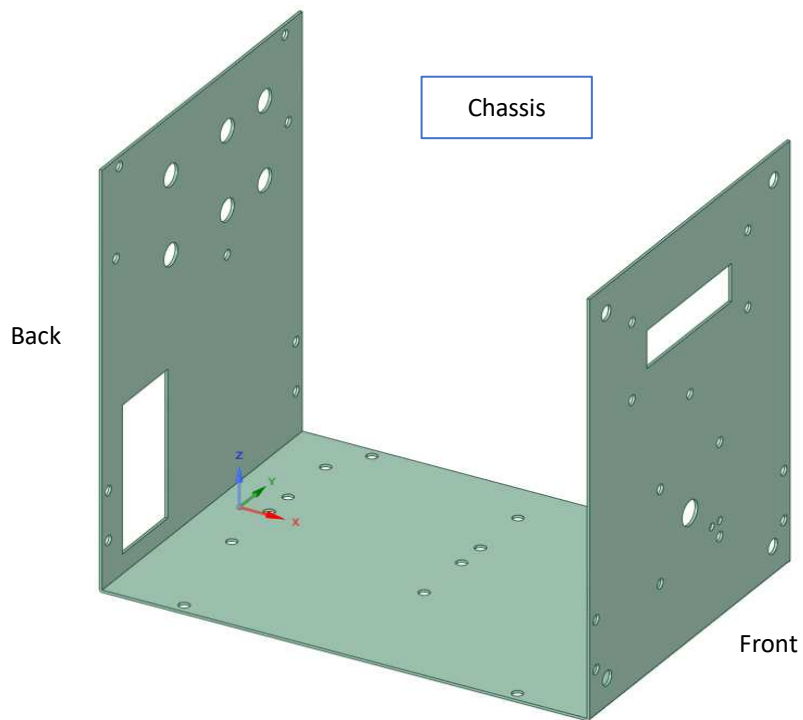

The Top Cover has the same shape as the Chassis.

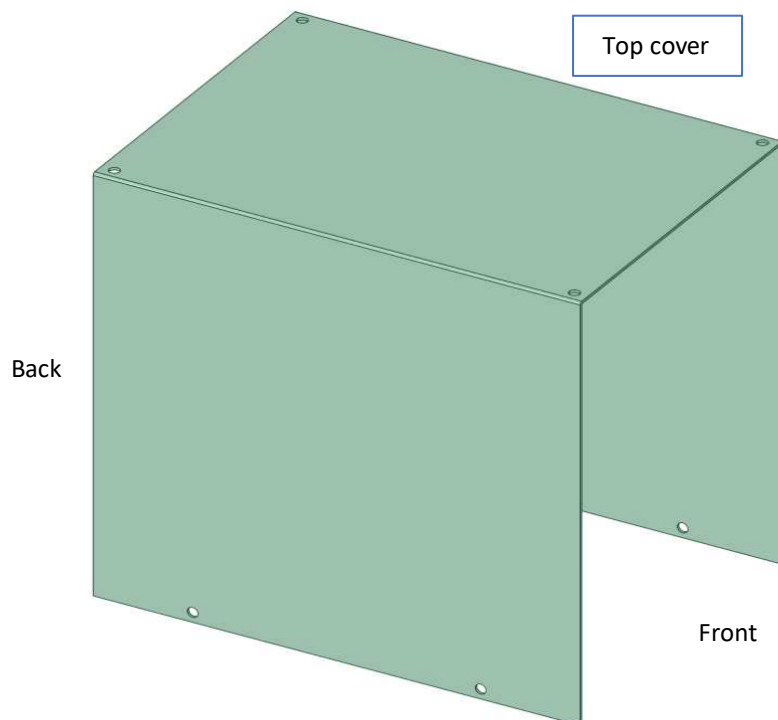

### Front panel design

#### \* Front panel construction

\* The printed sheet is inserted between the front and clear panels.

\* EVR-3 and EVR-DISP1 are mounted on the chassis. The mount screws' heads and the front panel make a flush surface.

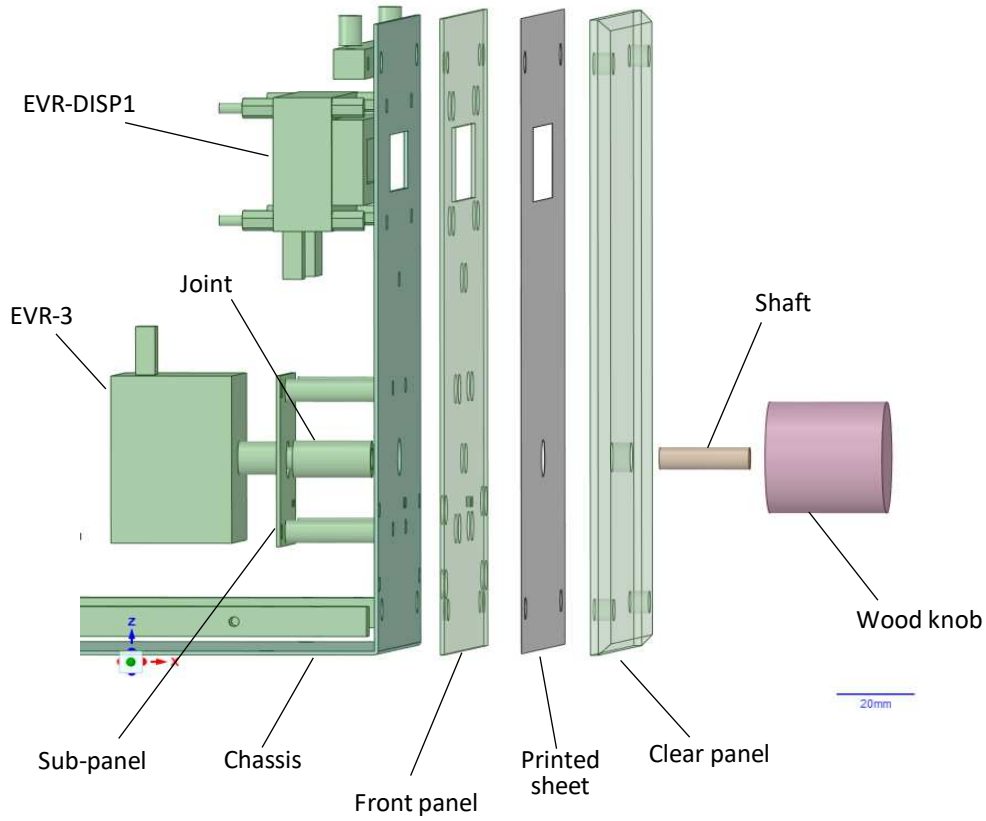

#### \* Part mounting

Each part is fixed on the chassis with slim head screws.

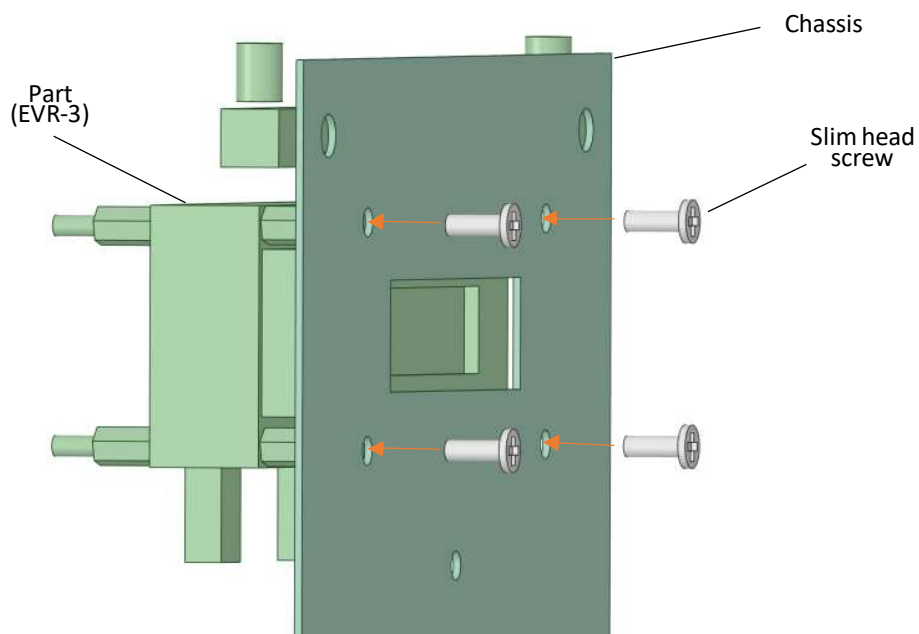

**\* Hiding screw heads**

- (1) The thickness of the Front Panel is equal to height of the screw heads.  
So, the Front Panel and the screw heads form flush surface.
- (2) The Printed Sheet covers the screw heads.

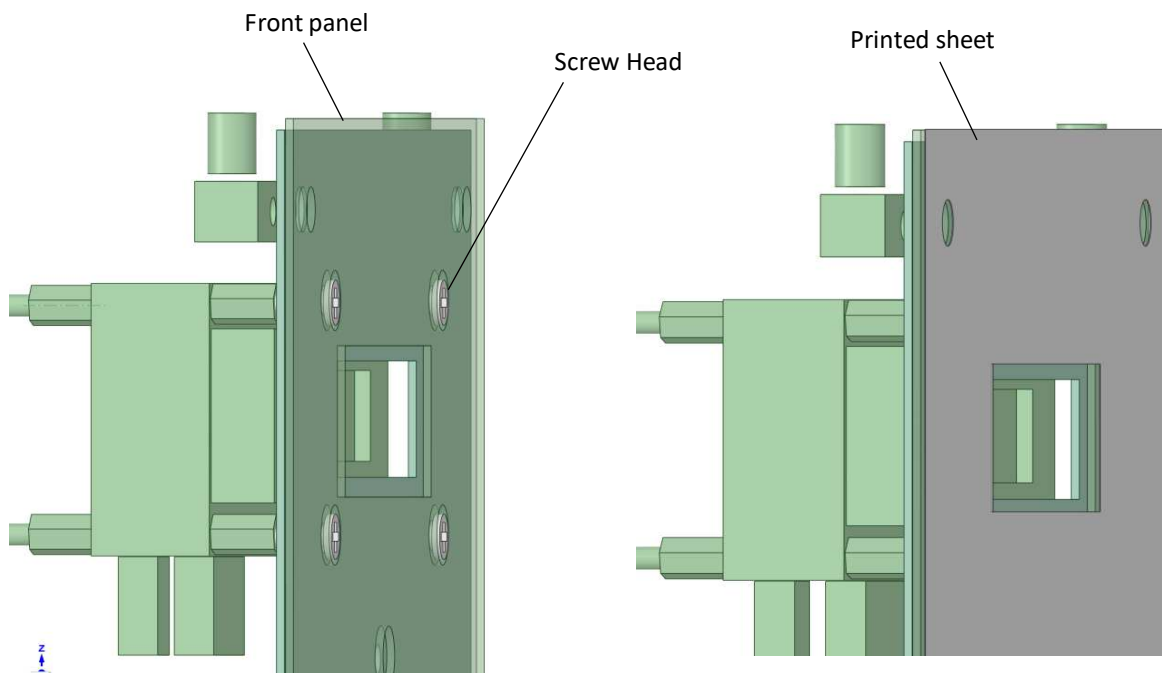
**\* Attaching Clear Panel**

The Front Panel, Printed Sheet and Clear Panel are fixed with four clear plastic screws.

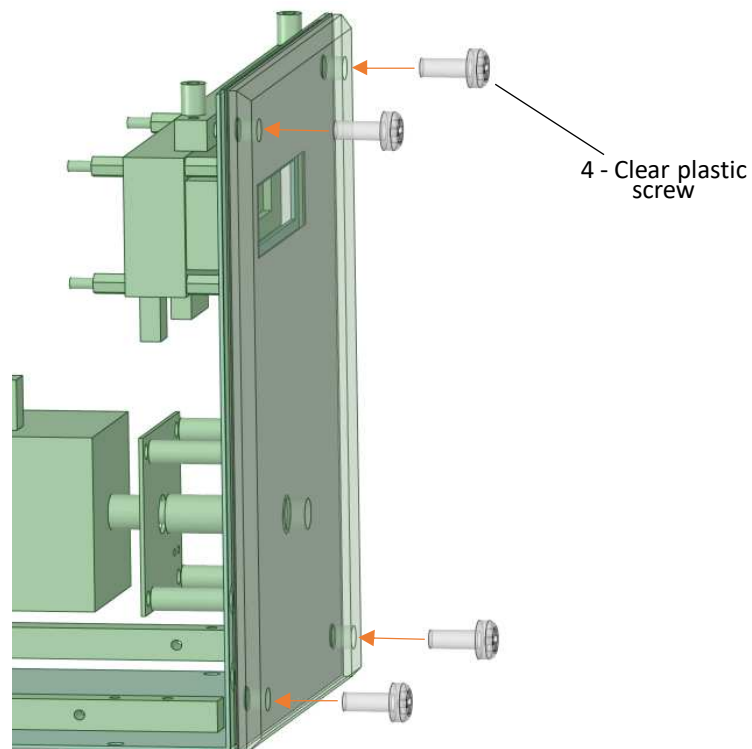

### Back Panel Design

The following parts are fixed on the Back Panel:

- Six RCA jacks

- Buffer Board

- AC inlet & switch module

The colored (white) panel is fixed to the chassis with seven (7) M3 slim head screws.

The colored panel forms flush surface with the heads of screws that fix Buffer Board and a soldering tab (fixed on the inner side of the chassis).

The panel-mount parts are attached after the enclosure is assembled.

Sticker is used for lettering.

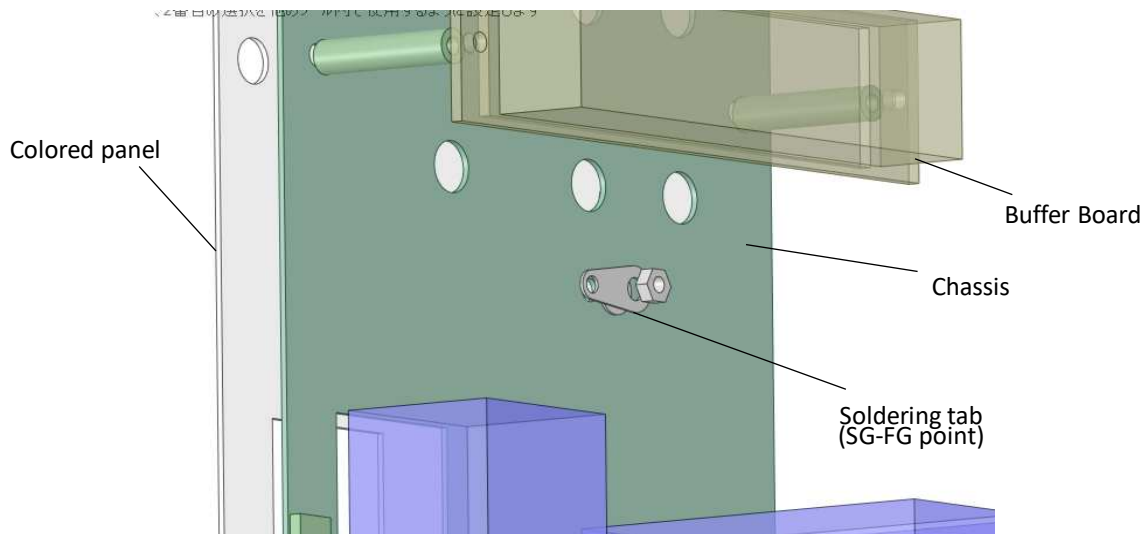
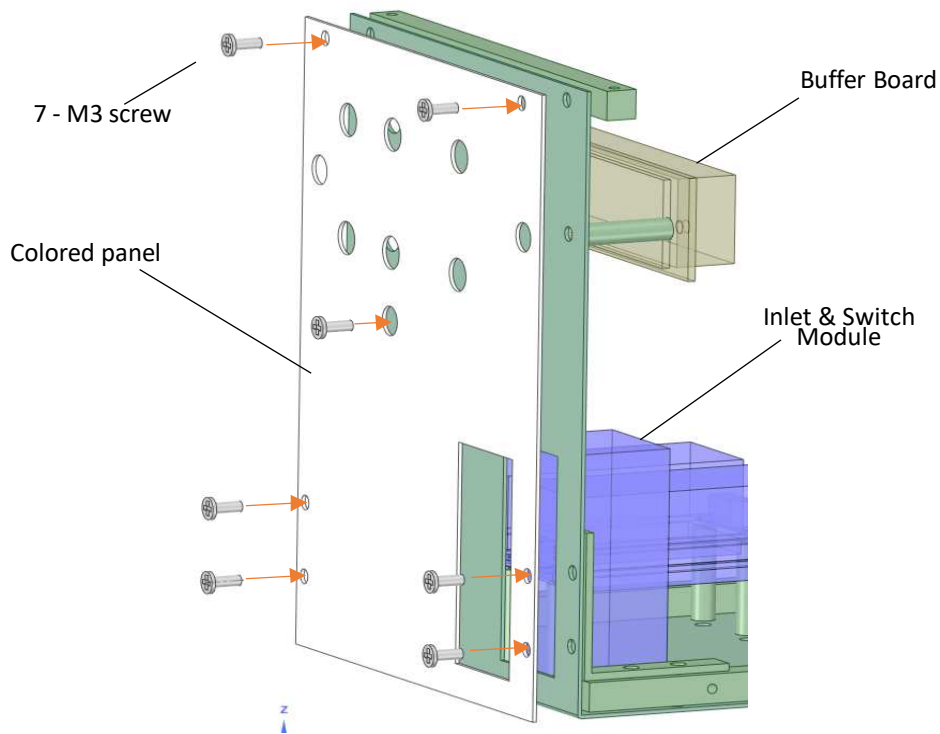

### Bottom Panel Design

As with the Front Panel and Back Panel, the Bottom Panel forms a flush surface with the slim head screws that fix the power supply modules.

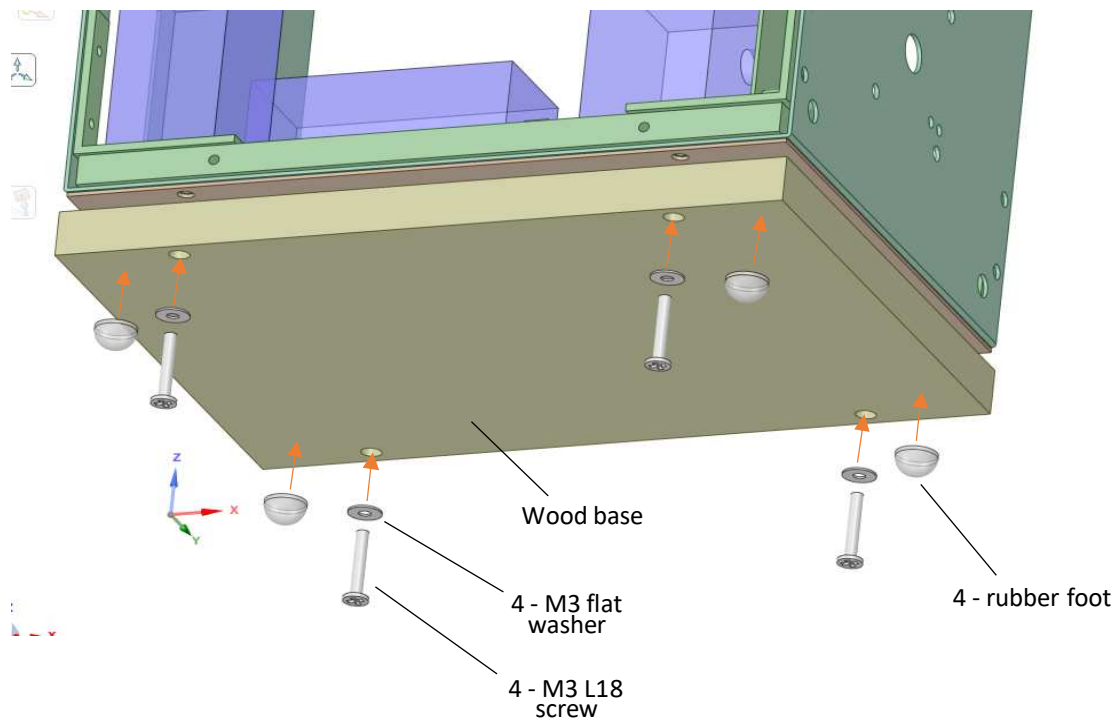
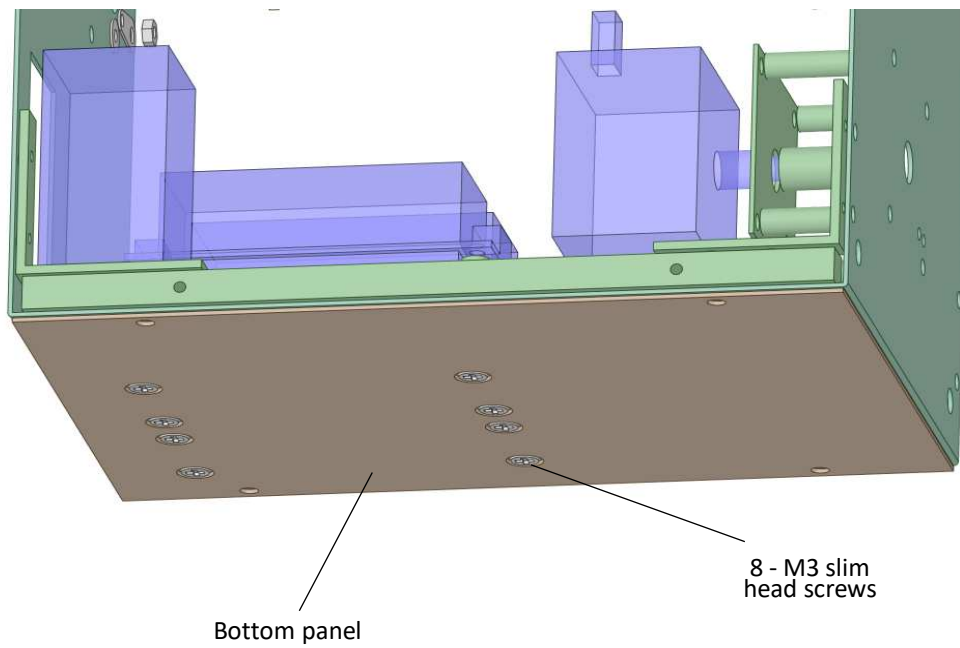

### Dimension of parts

#### \* Chassis (PN1)

Aluminum, t=1 mm, not painted, to be bent into horseshoe shape

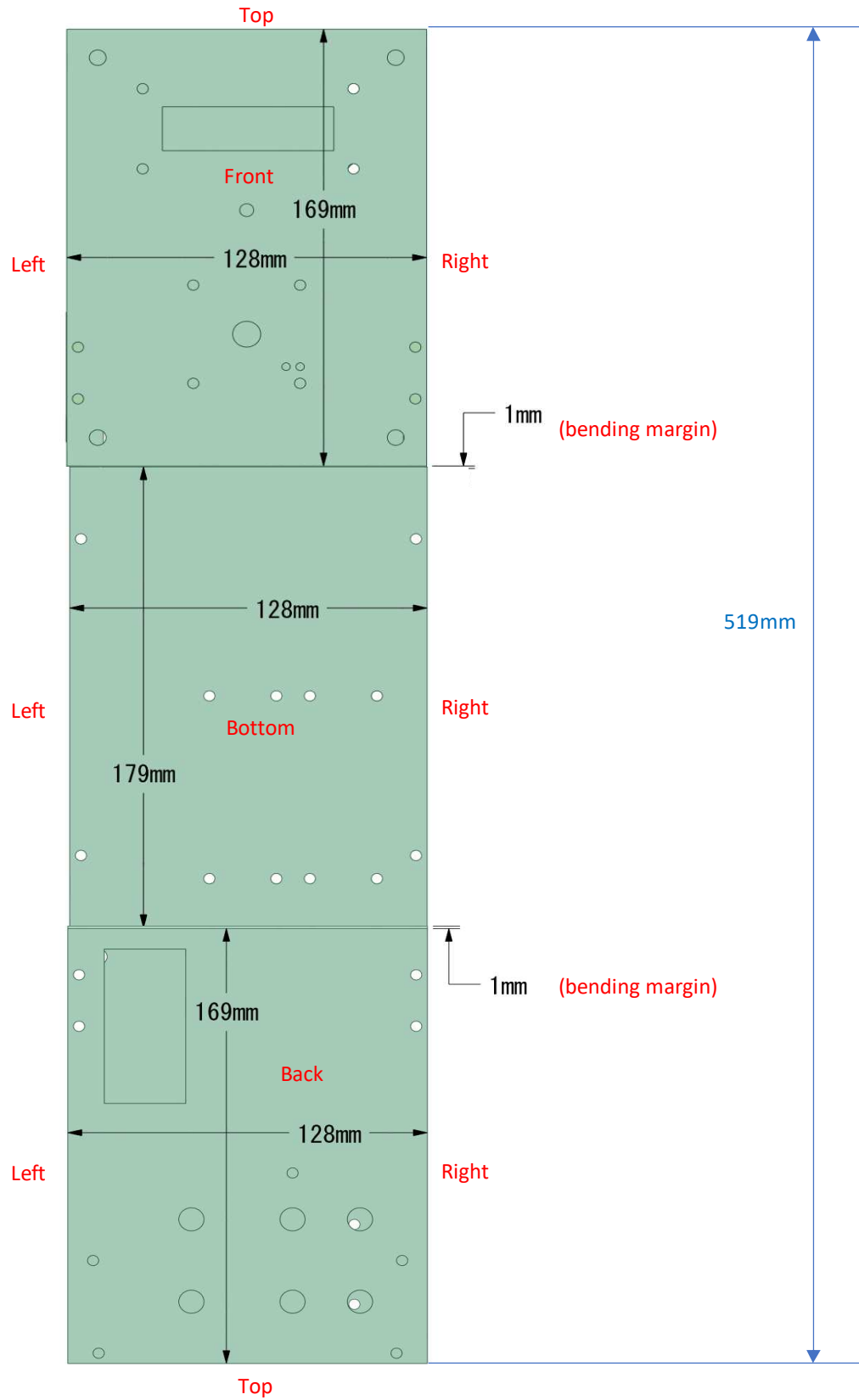

\* Cutouts of Chassis (PN1)

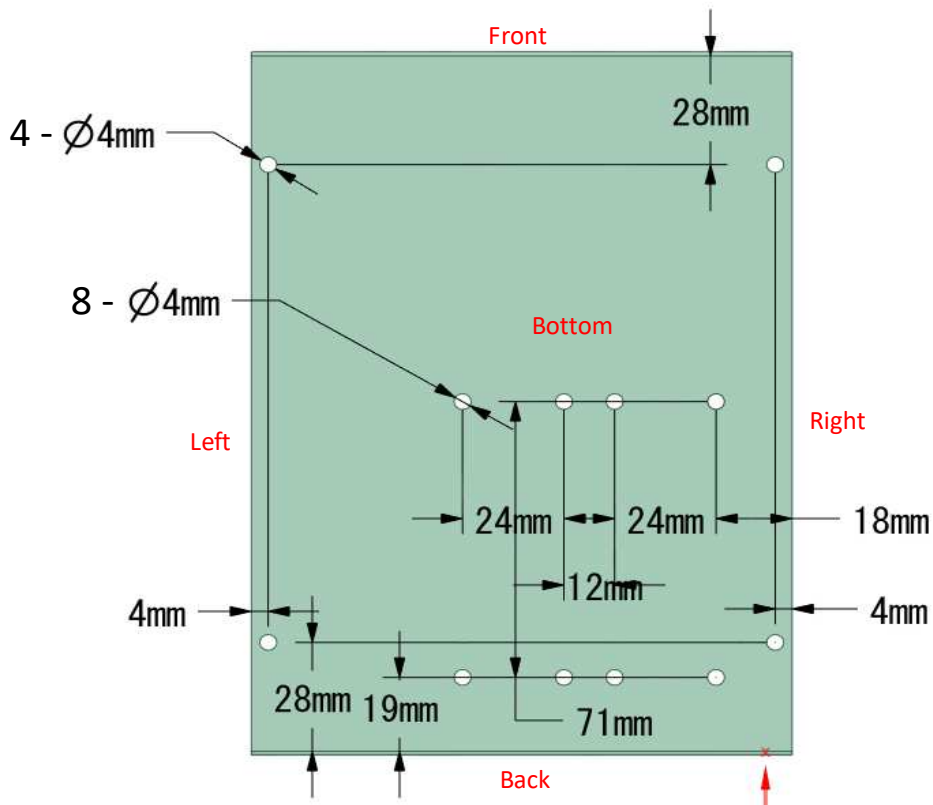
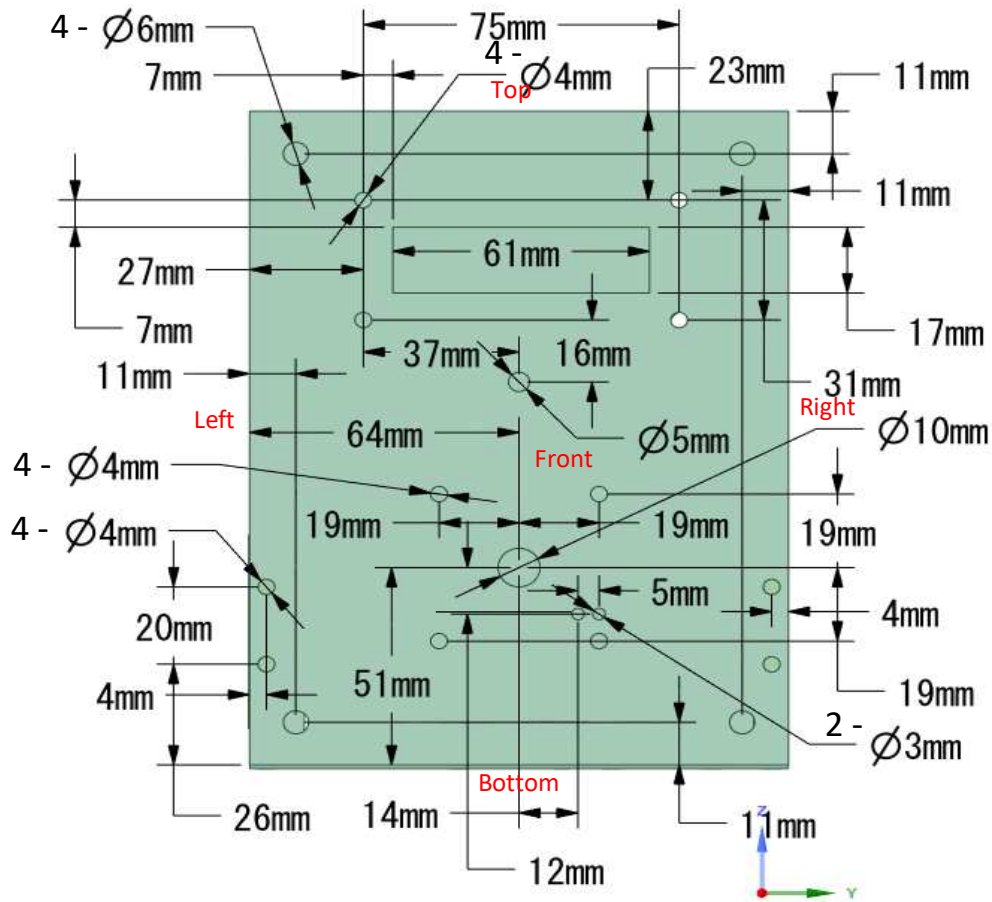



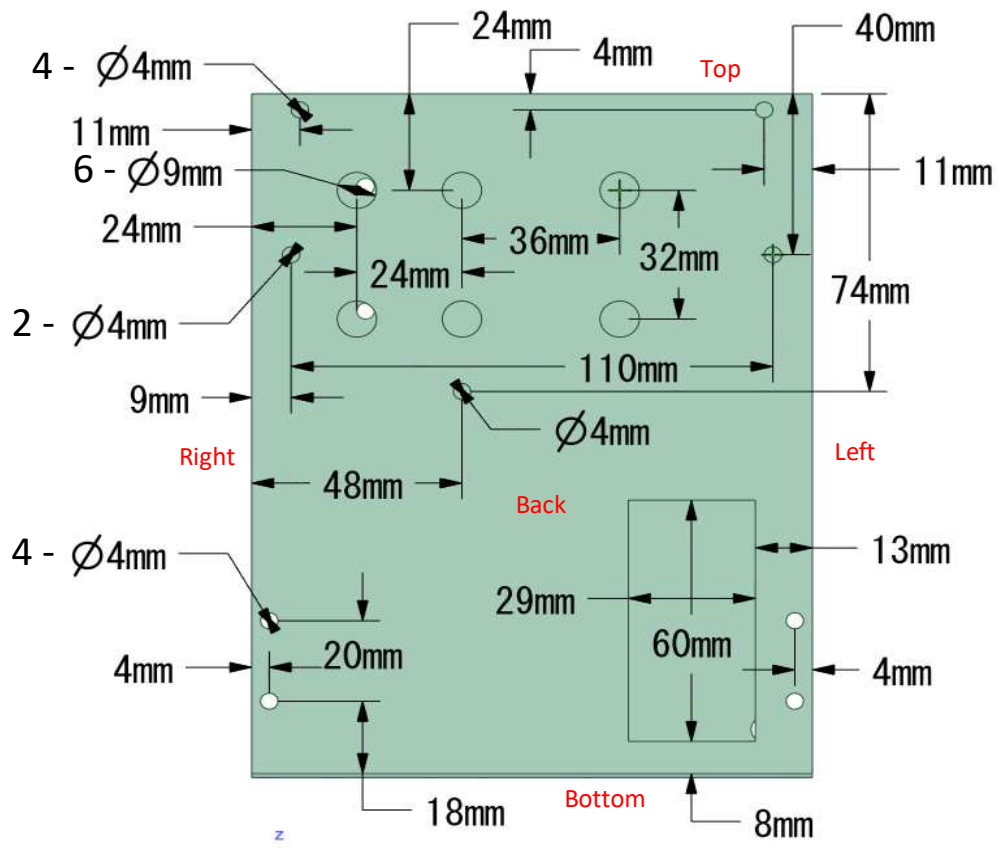

**\* Top Cover (PN2)**

Aluminum, t=1mm, to be painted with antique paint, to be bent into horseshoe shape

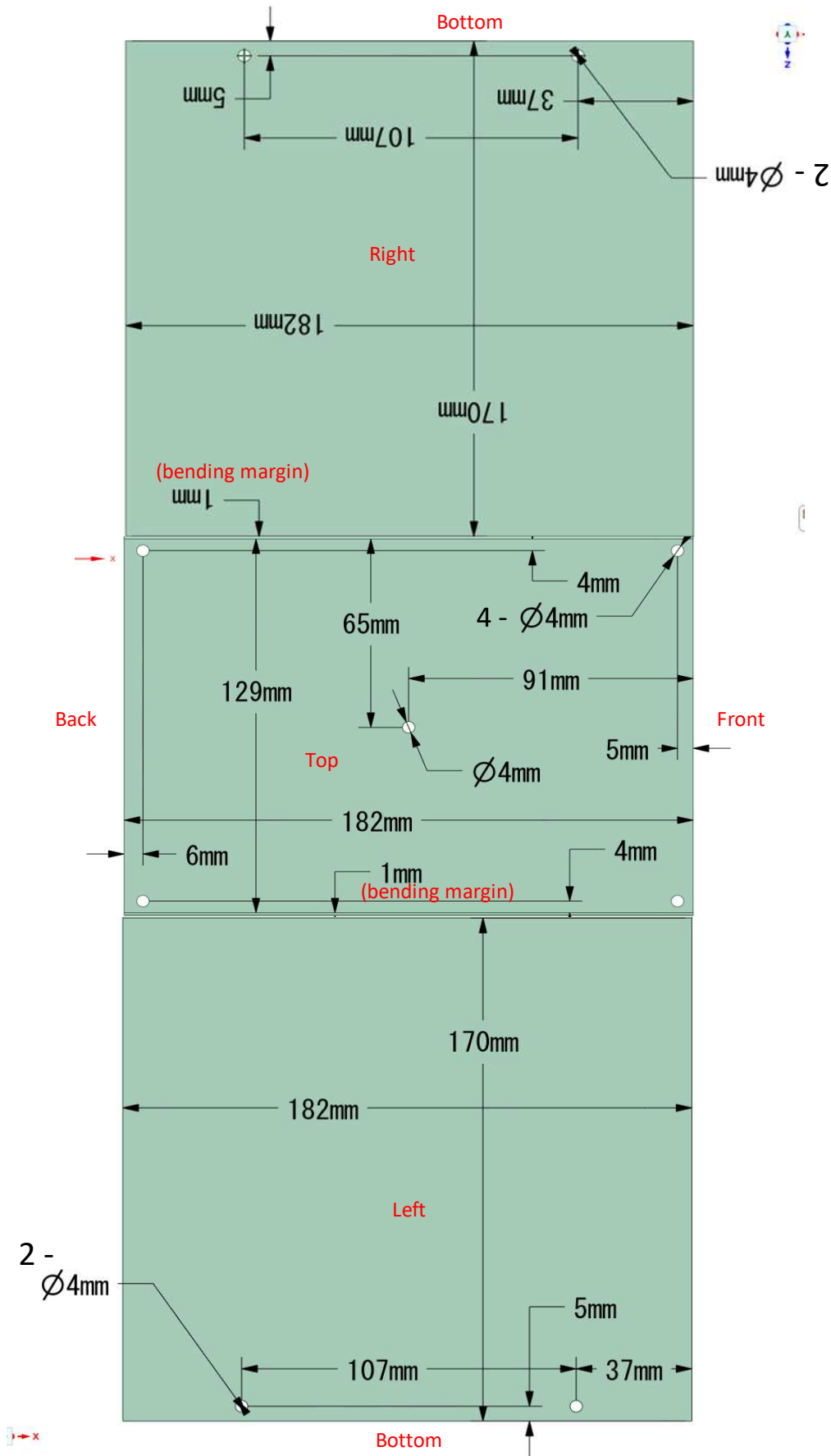

**\* Front Panel (PN3)**

Aluminum, t=1mm, painted white

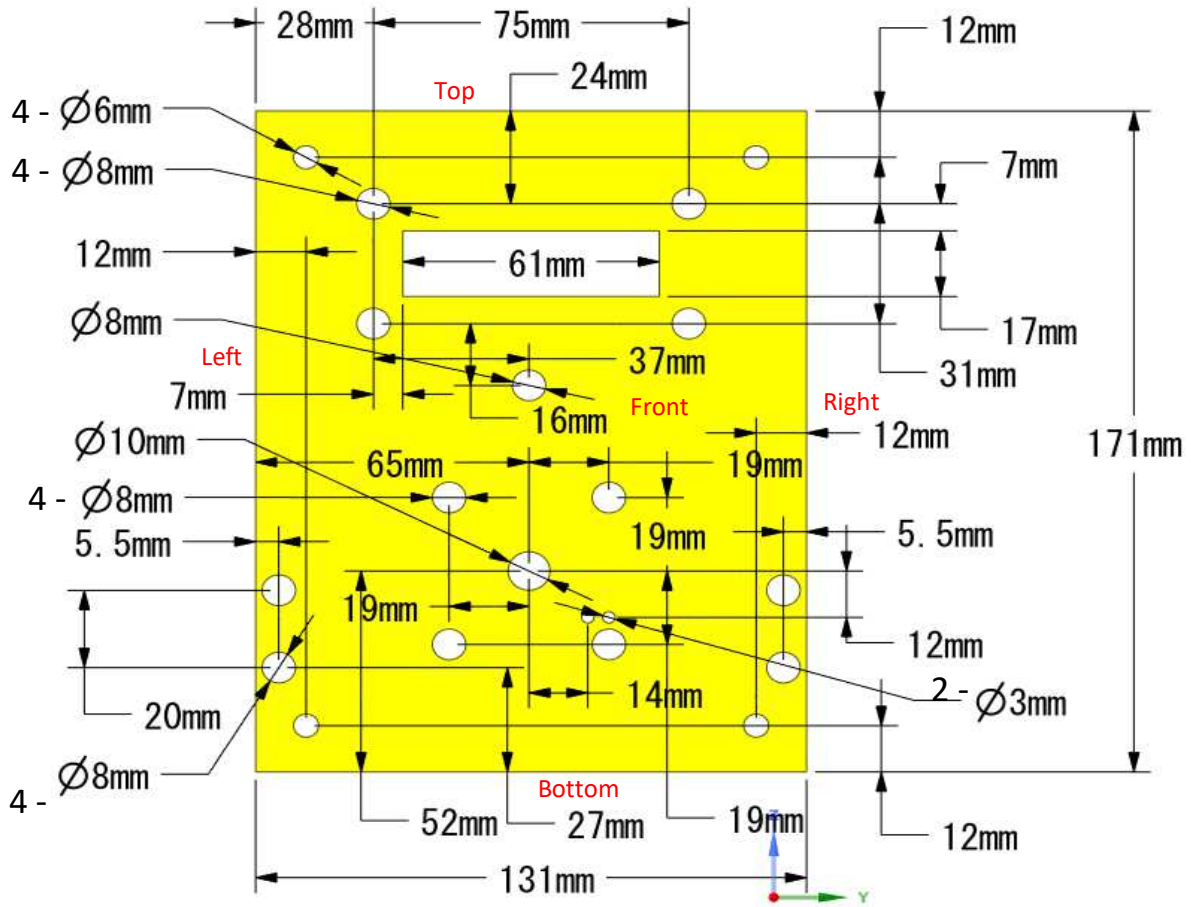

**\* Bottom Panel (PN4)**

Aluminum, t=1mm, not painted

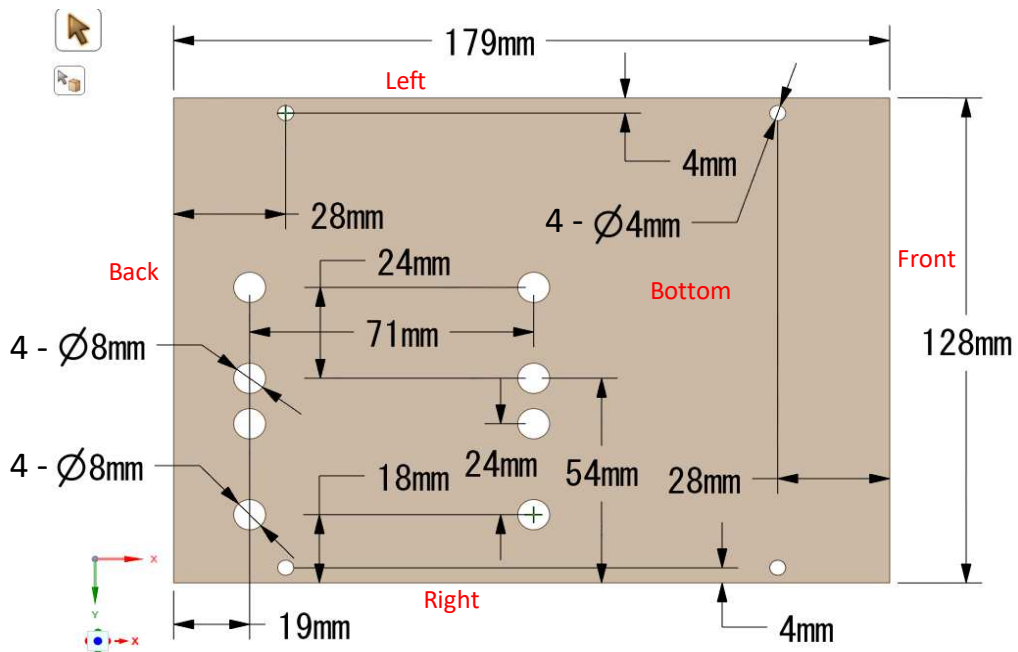

**\* Wood Base (PN5)**

Plywood, t=12mm, painted black

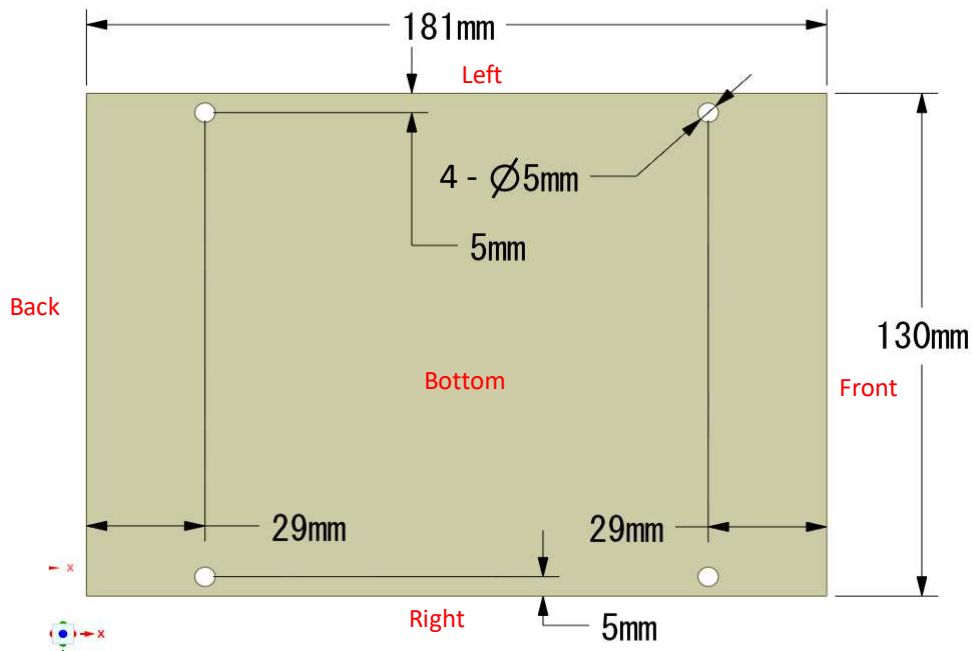

**\* Back Panel (PN6)**

Aluminum, t=1mm, painted white

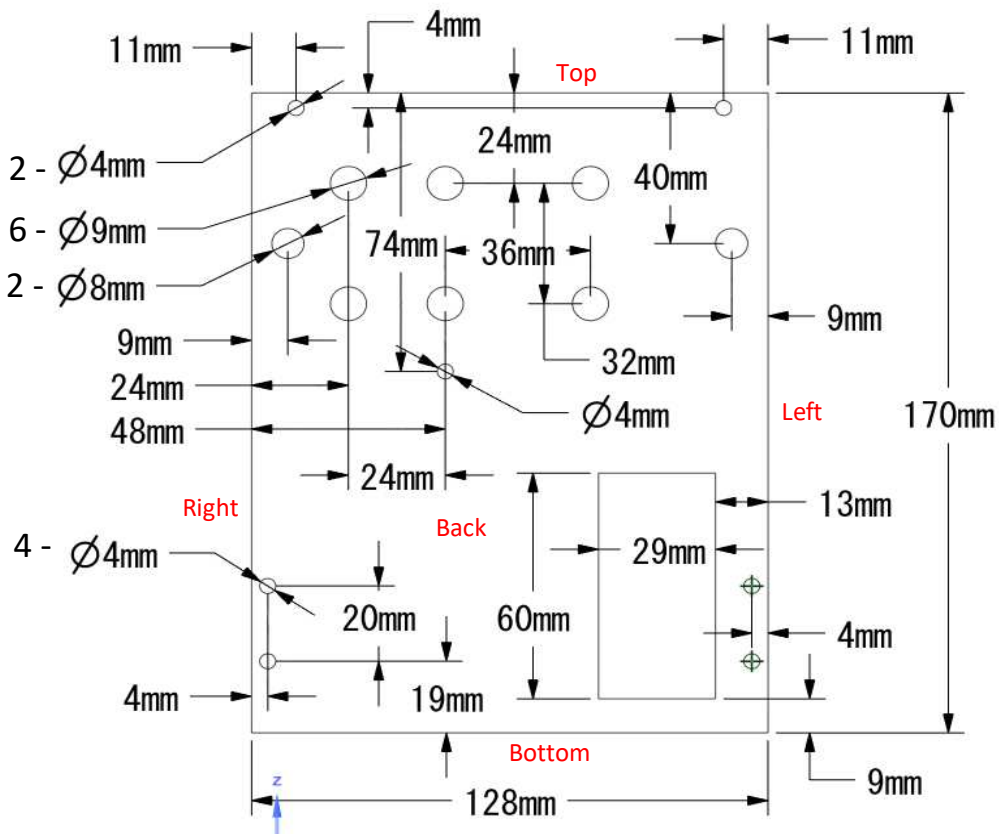

**\* Clear Panel (PN7)**

Acrylic, t=5mm, clear, already processed except the shaft hole

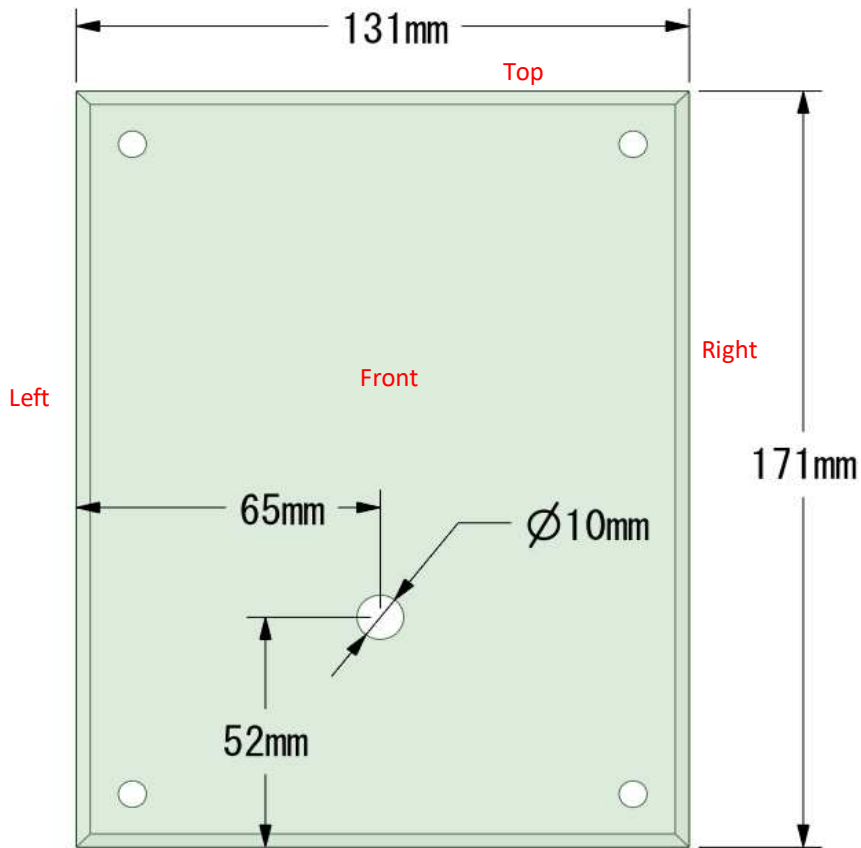

**\* VR Panel (PN8)**

Aluminum, t=1mm, not painted

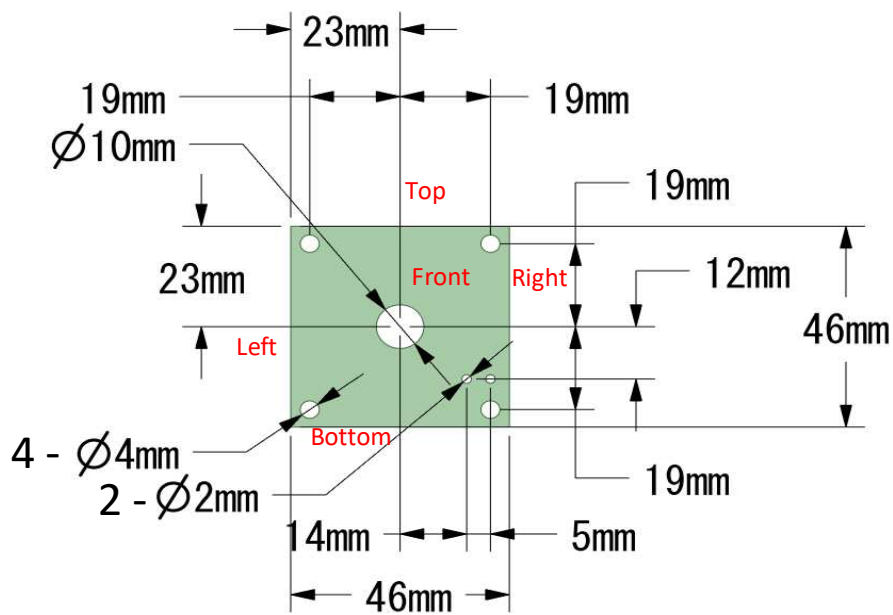

**\* Square Bar Left (SB1)**

Aluminum, 8x8mm, not painted  
 2.4mm holes to be tapped in M3

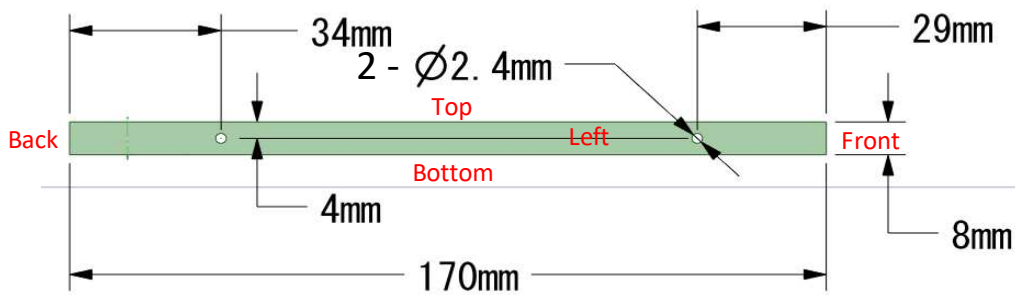
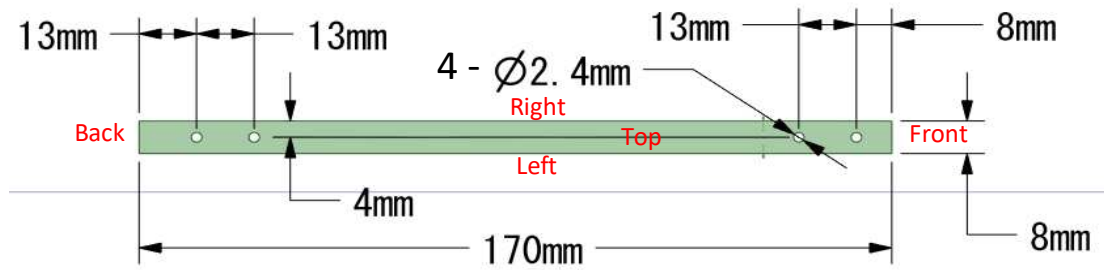

**\* Square Bar Right (SB2)**

Aluminum, 8x8mm, not painted  
 Exactly the same dimension as SB1

**\* Square Bar Top (SB3)**

Aluminum, 8x8mm, not painted  
 4.1mm holes to be tapped in M5

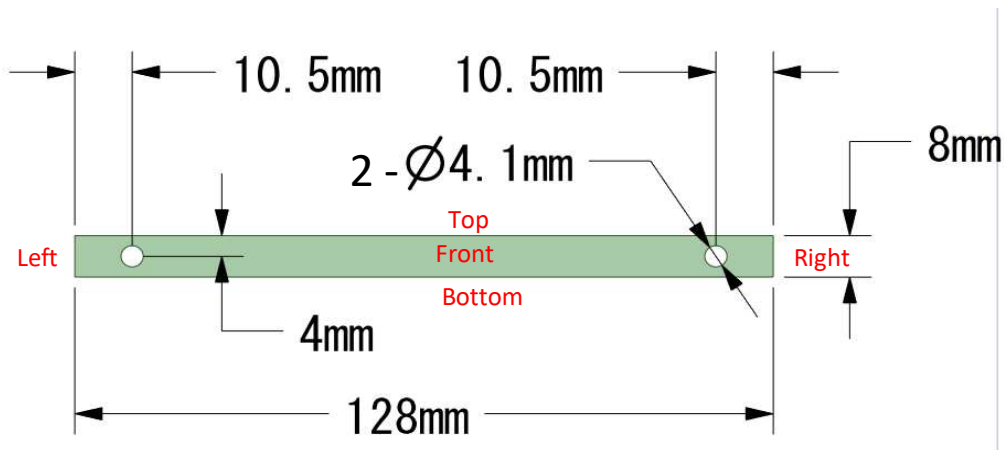

2.4mm holes to be tapped in M3

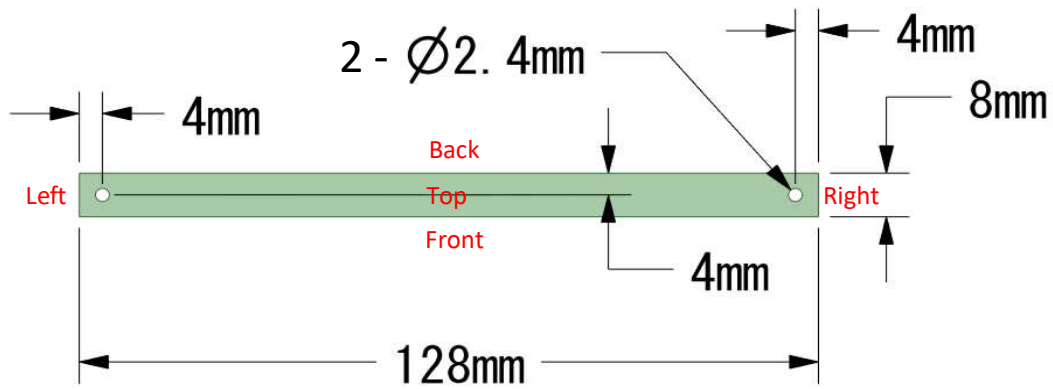

**\* Square Bar Back (SB4)**

Aluminum, 8x8mm, not painted

2.4mm holes to be tapped in M3

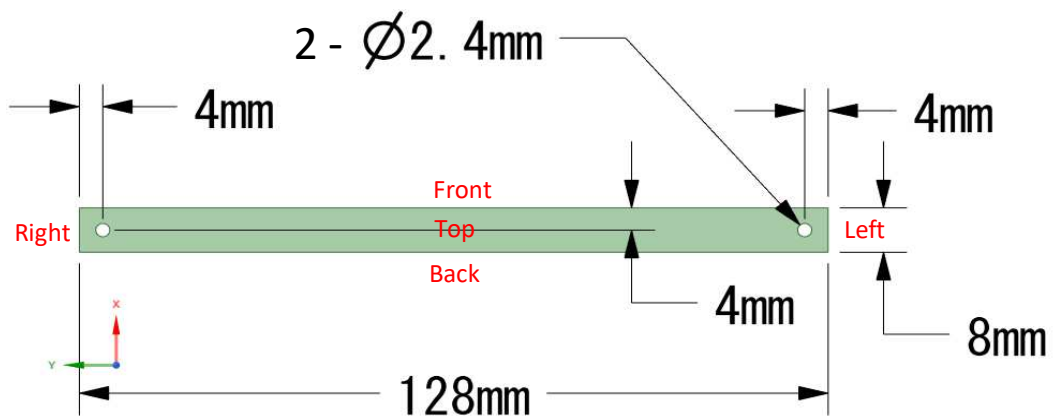
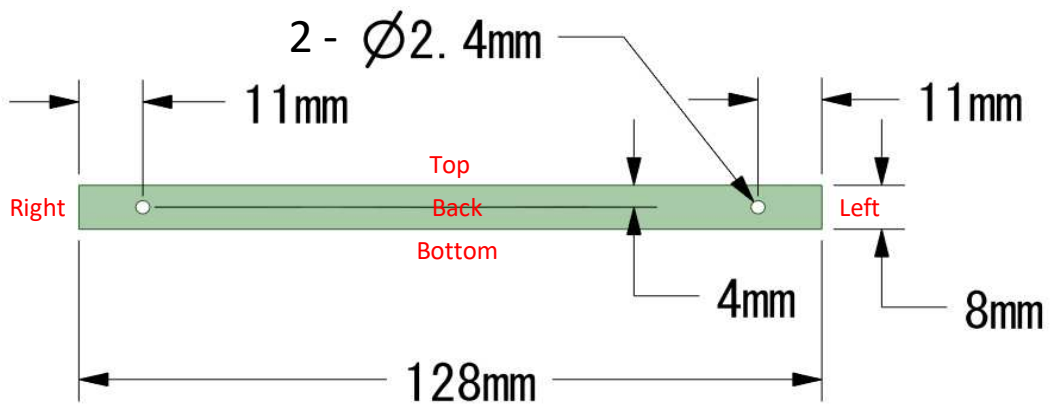

**\* Square Bar Left Upper (SB5)**

Aluminum, 8x8mm, not painted

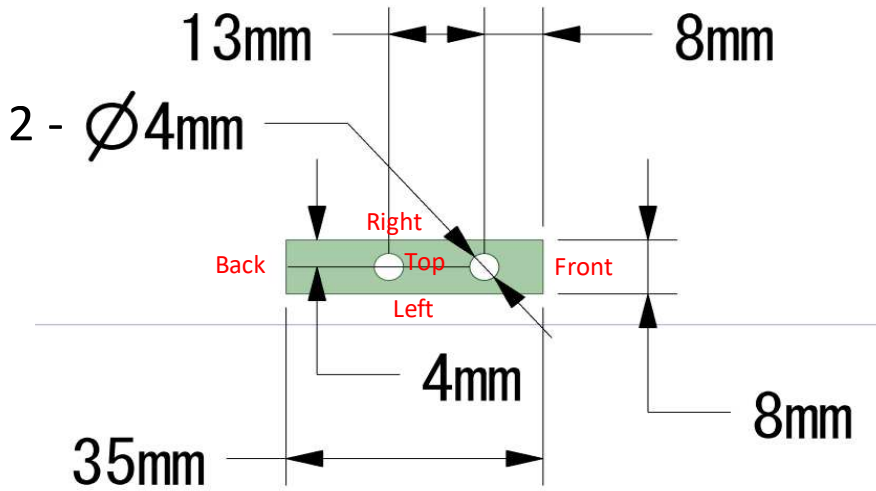

**\* Square Bar Right Upper (SB6)**

Aluminum, 8x8mm, not painted

Same dimension as SB5

**\* L-shape Angle (AG1)**

Aluminum, t=2mm, not painted

2.4mm holes to be tapped in M3

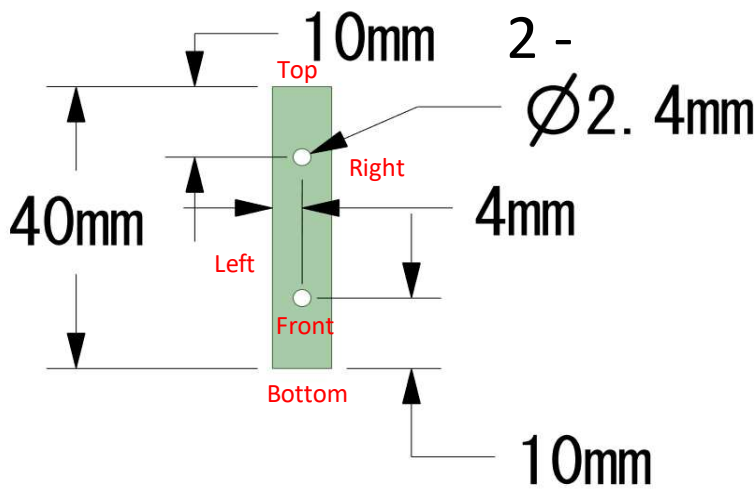



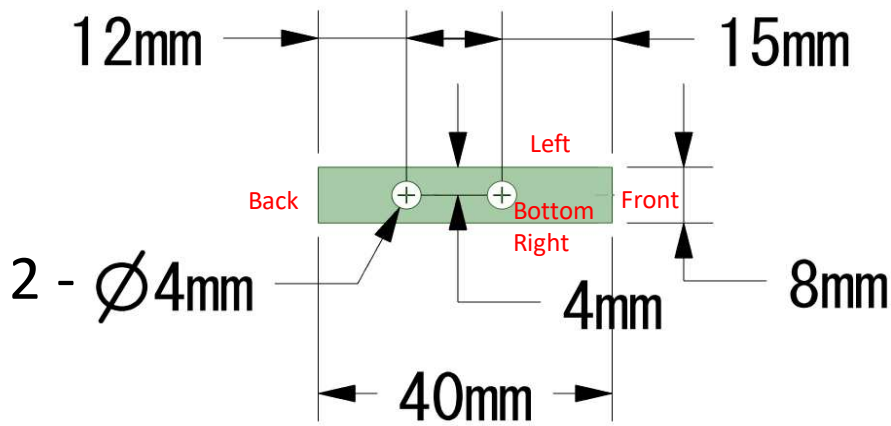

\* **L-shape Angle (AG2)**

Exactly the same dimension as AG1

\* **L-shape Angle (AG3)**

Exactly the same dimension as AG1

\* **L-shape Angle (AG4)**

Exactly the same dimension as AG1

\* **Knob (RB1)**

Ebony wood,  $\Phi=30$ ,  $L=25$ , not painted

6.2mm holes is 13mm deep

6.2mm hole is chamfered with 6.8mm drill

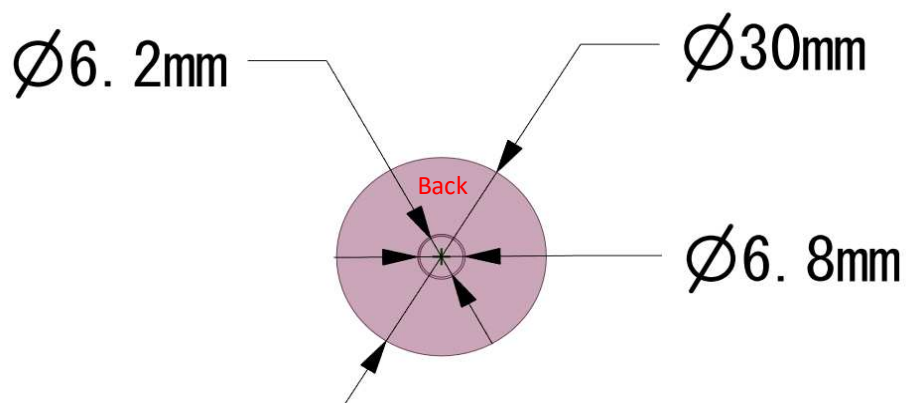

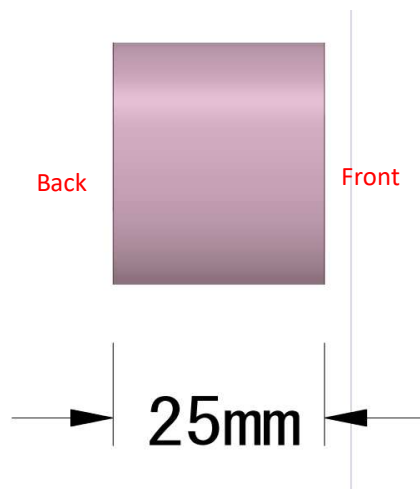
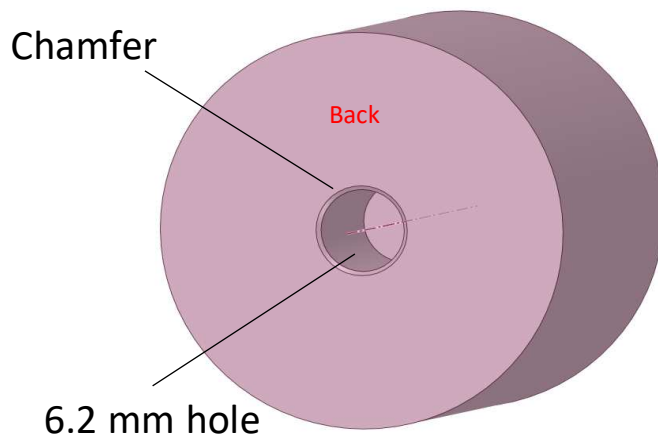

**\* Shaft (RB2)**

Bakelite, not painted  
Length to be adjusted

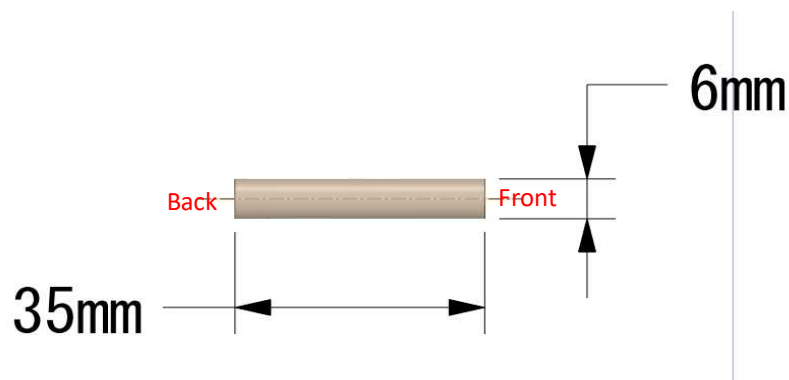

**\* Printed sheet (SK1)**

A4 (210 x 297mm), white, removeable sticker (A-one #28874)

To be printed with PC and printer

This sheet is exchangeable

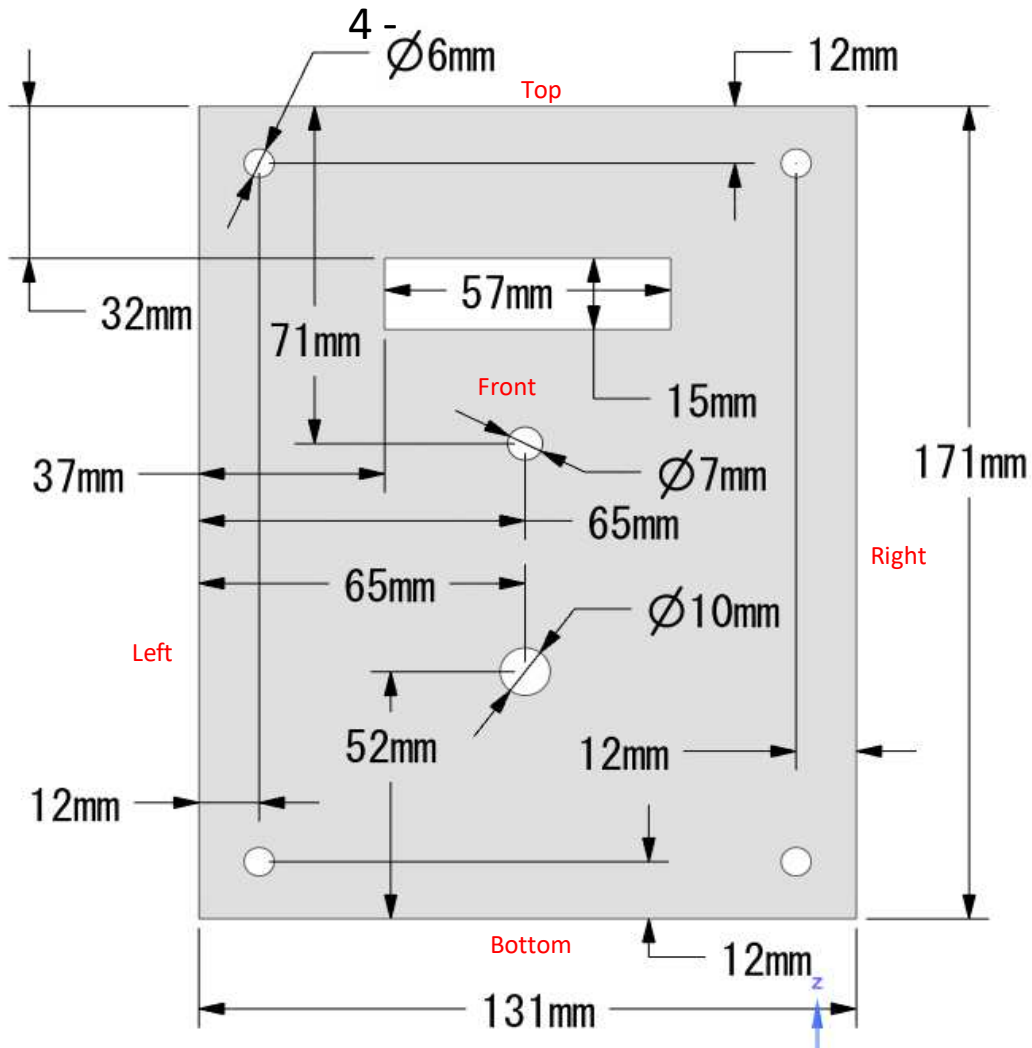

Print examples



**\* Sticker 1 (SK2)**

Postcard size (100 x 140mm), transparent, sticker (A one #29394)

To be printed with PC and printer

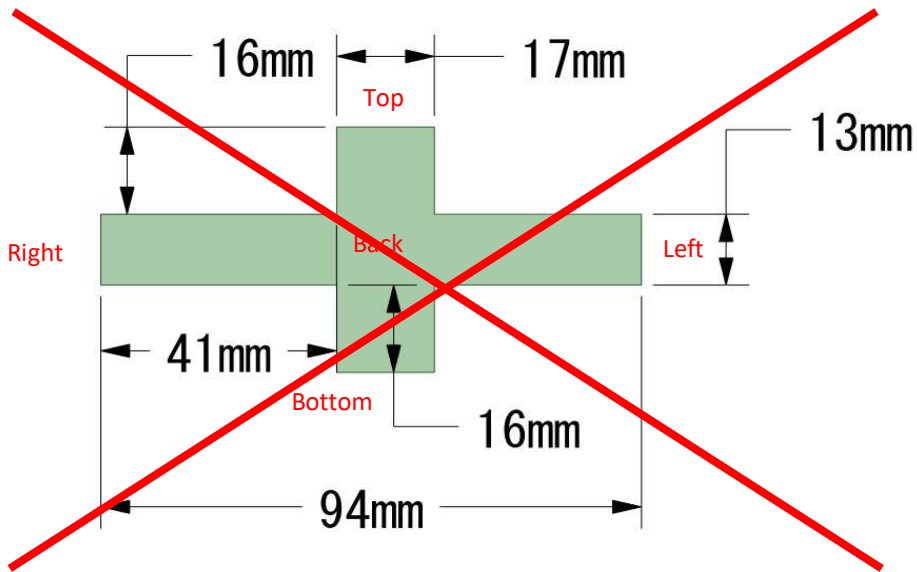

**\* Sticker 2 (SK3)**

Postcard size (100 x 140mm), transparent, sticker (A one #29394)

To be printed with PC and printer

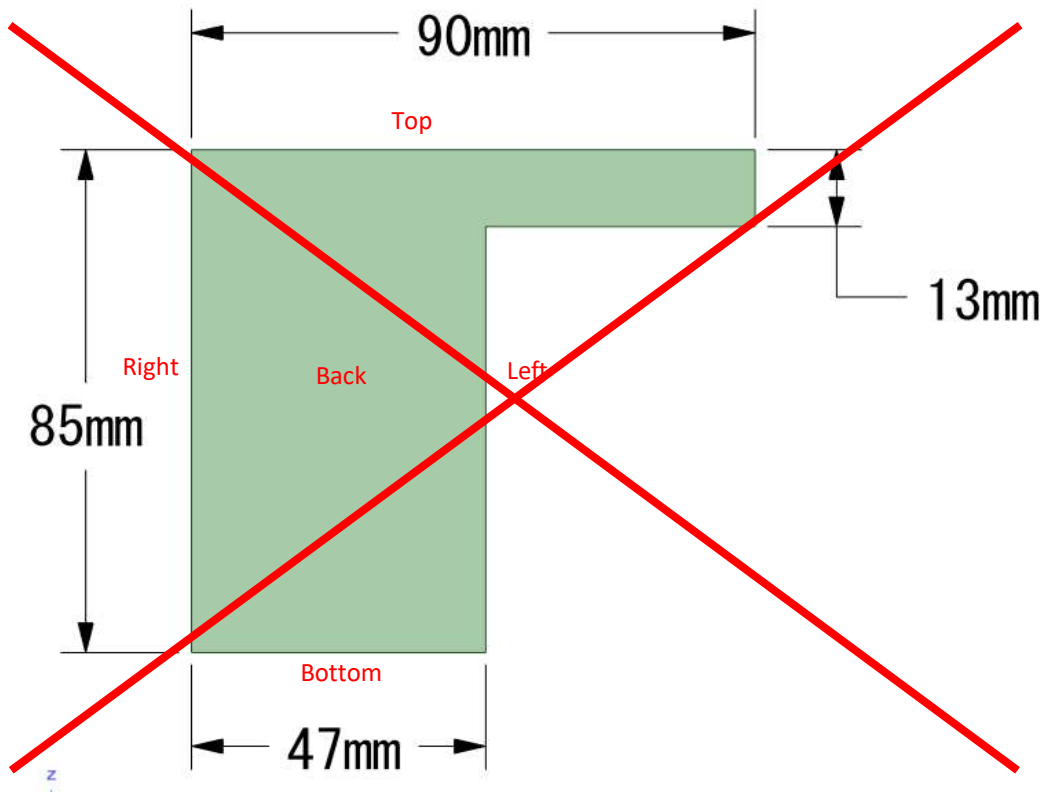

Example of SK2, 3

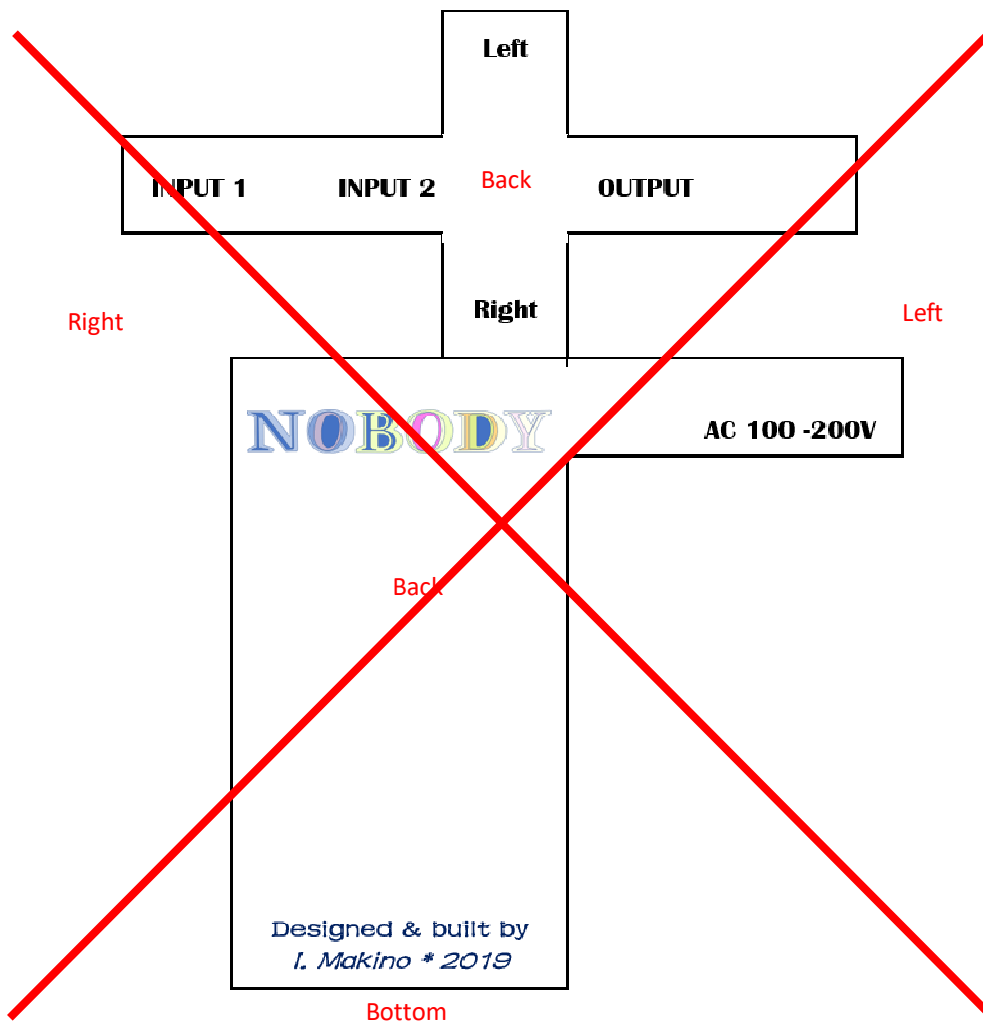

The sticker for Back Panel (SK2) covers the entire Back Panel (PN6) just like Front Panel.

**\* Sticker 1 (SK2)**

A4 size (210 x 297mm), white sticker (A-one #29421)

To be printed with PC and printer

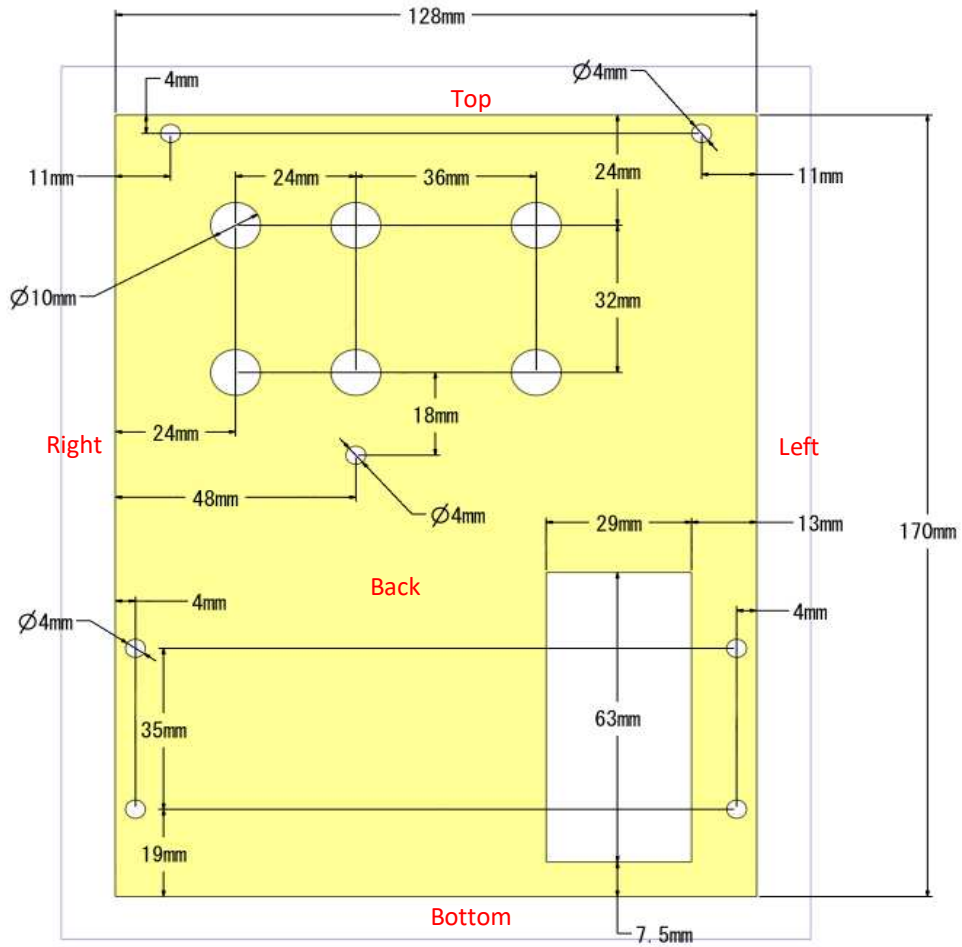

Print example

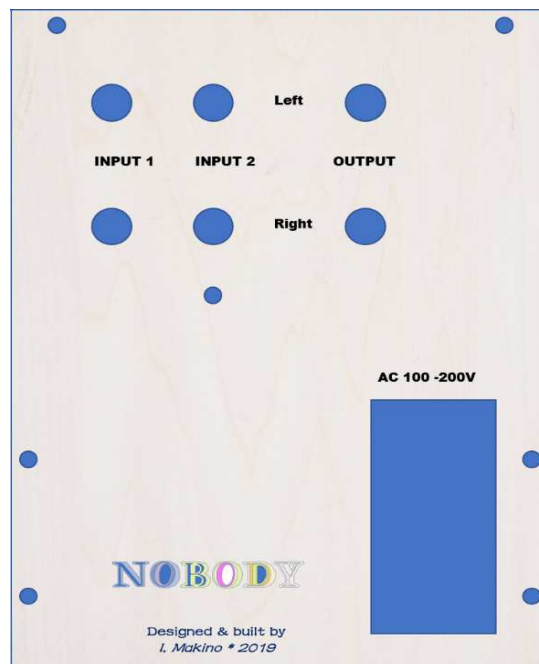

[END OF DOCUMENT]